

Optimized Multispectral Palm print Recognition System based on Contourlet Transform

Faseela Harshad
Mtech Student
KMCTCE

Alphonse Devasia
Assistant Professor
KMCTCE

ABSTRACT

Reliability and accuracy in personal identification system is a dominant concern to the security world. Many types of personal identification systems have been developed, and palmprint identification is one of the emerging technologies that attracted the researchers due to its stable and unique characteristics. Recently, multispectral imaging has attracted considerable attention as it can acquire more discriminative information in a short time. This paper presents a novel biometric technique to automatic personal identification system using multispectral palmprint technology. In this method, each of spectrum images are aligned and then used to extract palmprint features using Contourlet Transform CT. It is a multiresolution and multidirection transform which can be effective in capturing the palm features. Finally, Genetic Algorithm is used for feature selections in order to have high performance. The expected results showed that the proposed method achieve an excellent identification rate and provide more security in noisy environment.

General Terms

Palmprint Recognition, Feature Extraction, Feature Selection

Keywords

Palmprint Recognition, Contourlet Transform, Genetic Algorithm

1. INTRODUCTION

Today, the area of personal identification is exploiting computer-aided systems as a safer and more robust method and biometrics is one of the most reliable features that can be used in computer-aided personal recognition. Inconvenience with using the traditional methods caused a rapid increase in the application of biometrics [2]. The common place biometric features are fingerprints, facial features, iris patterns, speech patterns, hand geometry, and palmprints. The rich texture information of palmprint offers one of the powerful means in personal identification. This information mainly includes the principal lines, the wrinkles and the fine ridges [4]. Palmprint recognition owns many merits, such as high accuracy, high user-friendliness and low cost. However, in order to improve the palmprint systems, especially in the aspects of accuracy and its vulnerability to spoof attacks multispectral imaging is an effective solution. It is possible to simultaneously capture images of an object in the visible spectrum and beyond. Palm images from the polyU palmprint database are used. In this paper, we first propose a multispectral palmprint identification algorithm. The objective of this paper is to extract the region of interest from the palmprint. The Contourlet transform is applied to extract features. Energies are calculated for each subband as feature

selection process. The Genetic Algorithm is used to determine the final biometric classification.

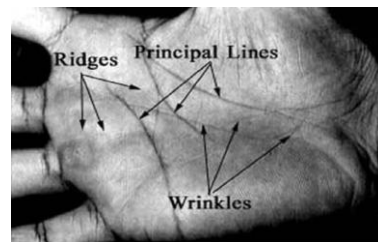

Fig 1 : Palmprint features

The rest of this paper is organized as follows: section 2, we briefly explain the typical palmprint recognition system. We then outline the Multispectral image fusion. In section 3 we describe the feature extraction by Contourlet Transform and feature selection using Genetic Algorithm. Then Experimental results are shown in Section 4. Finally, the paper is concluded in Section 5.

2. PROPOSED SYSTEM

The proposed system consists of multispectral image fusion, preprocessing, feature extraction, matching and decision stages [4] which is illustrated in Fig 2. Multi spectral imaging is a new technique in remote sensing, medical imaging and machine vision that generate several images corresponding to different wavelengths. This technique can be give different information from the same scene using an acquisition device to capture the palmprint images under visible and infrared light resulting into four color bands (RED, BLUE, GREEN or Near-IR (NIR). The idea is to employ the resulting information in these color bands to improve the performance of palmprint recognition.

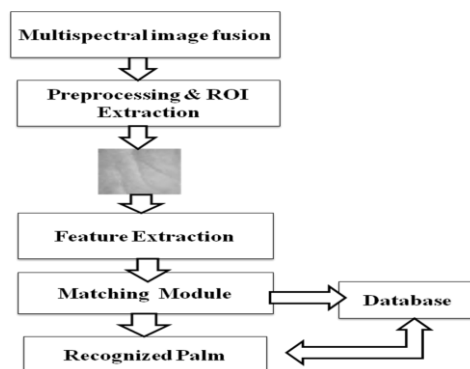

Fig 2: Block diagram of proposed system

In some cases principal lines and wrinkles are not enough to discriminate palms since there are many palms with similar line features also sometimes the lines (principal lines and major wrinkles) are difficult to be extracted because some palmprints are very unclear, so to overcome these problems and improve the accuracy of palmprint identification we can choose multispectral imaging which captures an image in a variety of spectral bands[6] [7].

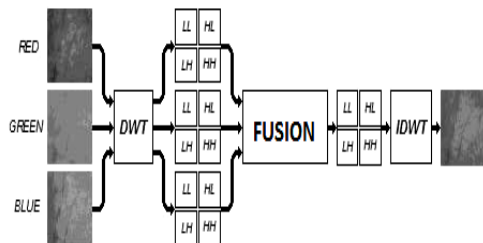

Fig 3: Multispectral image level fusion of Blue, Green and Red palmprint images

The image fusion extracts information from each source image and obtains the effective representation in the final fused image. The aim of image fusion technique is to process the detailed information that is found from both the source images[10]. To enhance the performance of palmprint identification, two or more spectrum of palmprint images are fused as shown in Fig. 3 (for Blue, Green and Red). Single level DWT is applied on these images to obtain the detail and approximation wavelet bands for these images [4]. The proposed image fusion selects the larger absolute values of the two wavelet coefficients at each point. Therefore, a fused image is produced by performing an inverse wavelet transform which is based on integration of wavelet coefficients corresponding to the decomposed palmprint images. Preprocessing is used to correct distortions, align different palmprints, and to crop the region of interest for feature extraction [3]. Preprocessing commonly focuses on apply a low pass filter, such as Gaussian smoothing, to the original palmprint image then binarizing the palm images and Boundary tracking algorithm is used to obtain the boundaries of the gaps between the fingers and the key points are identified for establishing the coordinate system. After establishing the co-ordinate systems, the central part of the palm prints are segmented using Square based method. Finally, ROI of palm image which is cropped from palmprint image [3].

3. FEATURE EXTRACTION

Contourlet Transform CT are used for feature extraction, it is a directional transform, designed to capture the high frequency content like smooth contours and directional edges. The contourlet transform is a discrete extension of the curvelet transform that aims to capture curves instead of points. Contourlet Transform provides more efficient representation of an object because most natural images contain diverse orientation. The contourlet is mainly based on the Laplacian pyramid and the directional filter banks, as shown in Fig.4. In the Laplacian pyramid, the spectrum of the input image will be divided into the low pass, sub band and

the high pass sub band. Then, the low pass sub band will be down sampled by two both in the horizontal and vertical direction and passed to the next stage[1]. The high pass sub band will be further separated into several directions by the directional filter. DFB is designed to capture high frequency components (representing directionality), the LP part of the PDFB permits sub-band decomposition to avoid “leaking” of low frequencies into several directional sub-bands, thus directional information can be captured efficiently.

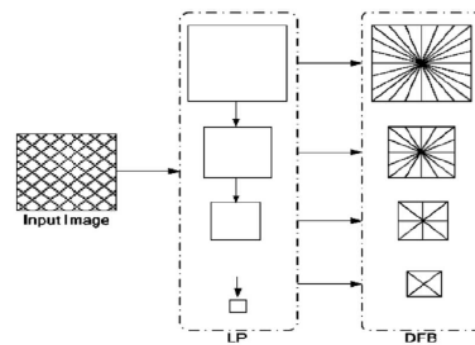

Fig 4: A flow graph of the Contourlet Transform

The contourlet expansion is composed of basis function oriented at various directions in multiple scales, with flexible aspect ratios[8]. With this rich set of basis functions, the contourlet transform effectively captures smooth contours that are the dominant feature in palmprint images. The Contour Code exhibits robust multispectral feature capturing capability. The contourlet transform is a new extension to the wavelet transform in two dimensions using non separable and directional filter banks. The contourlet transform uses contour segments and fine details in images to realize the local, multiresolutional and directional image expansion.

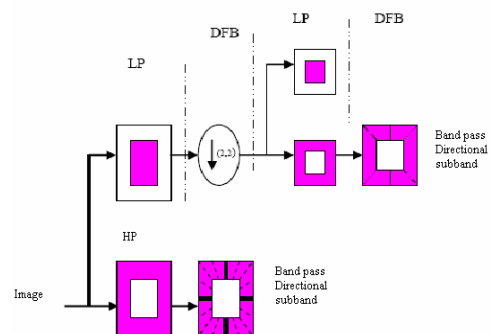

Fig 5 : Contourlet Model

Contourlet is implemented by the Pyramidal Directional Filter Banks PDFB that is a cascade of a Laplacian Pyramid (LP) and Directional Filter Banks (DFB). In contourlet transform, the Laplacian pyramid does the decomposition of images into sub-bands and then the directional filter banks analyze each detail image [1]. The contourlet transform has the multi-scale and time-frequency localization properties of wavelets, but

also offers a high degree of directionality and anisotropy [8]. These properties are very important in palmprint verification.

3.1 Energy calculation

The contourlet energy features CEFs are calculated as E1, E2, and E3. The large number of coefficients generated from the contourlet transform are minimized as a dimensionality reduction process, by calculating energies for each subband [1]. Palmprint matching is then performed by the classifier. In this work, feature dimension is reduced by calculating the following energy features from each subband as E1 – Mean and E2 – Standard deviation, E3 – Absolute Mean Energy.

$$E1(s, k) = \mu(s, k) = \frac{1}{MN} \sum_{i=1}^M \sum_{j=1}^N W_{s,k}(i, j)$$

$$E2(s, k) = \sigma(s, k) = \left[\frac{1}{MN} \sum_{i=1}^M \sum_{j=1}^N |W_{s,k}(i, j) - \mu_{s,k}| \right]^{\frac{1}{2}}$$

$$E3(s, k) = \frac{1}{MN} \sum_{i=1}^M \sum_{j=1}^N |W_{s,k}(i, j)|$$

M and N denote the number of rows and columns of the subband image, and s and k denote the index of scale and direction. W is the coefficient of row M and column N in subband indexed by s and k, μ and σ represent mean and standard deviation, respectively. Likewise, each computed energy value can be used as an element to form a feature vector, which is denoted as the energy feature vector. So we can achieve higher recognition rate using short feature vectors is desired.

3.2 Feature Selection Using GA

Genetic algorithms (GAs) are relatively insensitive to noise, they seem to be an excellent choice for the basis of a more robust feature selection strategy for improving the performance of our texture classification system. Genetic algorithms (GAs), a form of inductive learning strategy, are adaptive search techniques which have demonstrated substantial improvement over a variety of random and local search methods [5]. These algorithms are stochastic search methods that mimic the metaphor of natural biological evolution. It operates on a population of potential solutions applying the principle of survival of the fittest to produce better and better approximations to a solution. These algorithms model natural processes, such as selection, recombination, mutation. Fig 6 shows the structure of a simple Genetic algorithm.

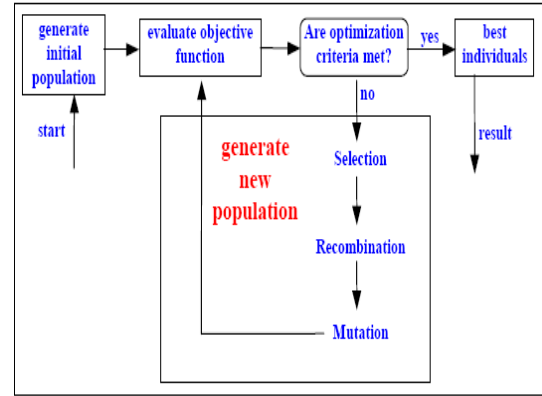

Fig 6: Structure of a single population Genetic algorithm

At the beginning of the computation a number of individuals (the population) are randomly initialized. The objective function is then evaluated for these individuals. The first/initial generation is produced. If the optimization criteria are not met the creation of a new generation starts. Individuals are selected according to their fitness for the production of offspring. Parents are recombined to produce offspring. All offspring will be mutated with a certain probability. The fitness of the offspring is then computed. The offspring are inserted into the population replacing the parents, producing a new generation. This cycle is performed until the optimization criteria are reached.

Genetic algorithms (GAs) are relatively insensitive to noise, they seem to be an excellent choice for the basis of a more robust feature selection strategy for improving the performance of our texture classification system. Genetic algorithms (GAs), a form of inductive learning strategy, are adaptive search techniques which have demonstrated substantial improvement over a variety of random and local search methods [5].

4. EXPERIMENTAL RESULTS

Experiments were performed using the multi-spectral palmprint database from the Hong Kong polytechnic university (PolyU). The database contains images captured with visible and infrared light. We selected 25 individuals palm images; every person has 6 and totaling up to 150. The experiments are conducted in MATLAB with image processing Toolbox. This approach performs better than using single feature based palmprint identification. The goal of this experiment was to evaluate the system performance when we fuse information from all spectrums of a palmprint images. The collected images in the database images might cause recognition problem as their quality is low because they collect in an uncontrolled environment with illumination variations and distortions. The proposed method shows that the False Alarm Rate (FAR) is almost zero up to 0.6 of Noise Variance, and at 0.8 of Noise Variance the FAR is only 10%. So it gives a better accurate system even in the presents of noise.

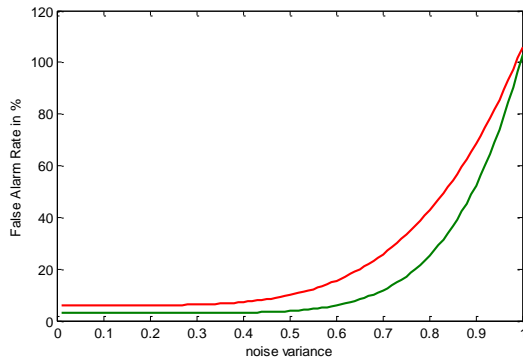

Fig 7 : Noise variance versus False Alarm Rate

Table 1. Accuracy in noisy environment

Database	Noise variance	FAR %	Accuracy
150 samples	0.2	2	98
	0.4	4	98
	0.6	6	94
	0.8	10	90

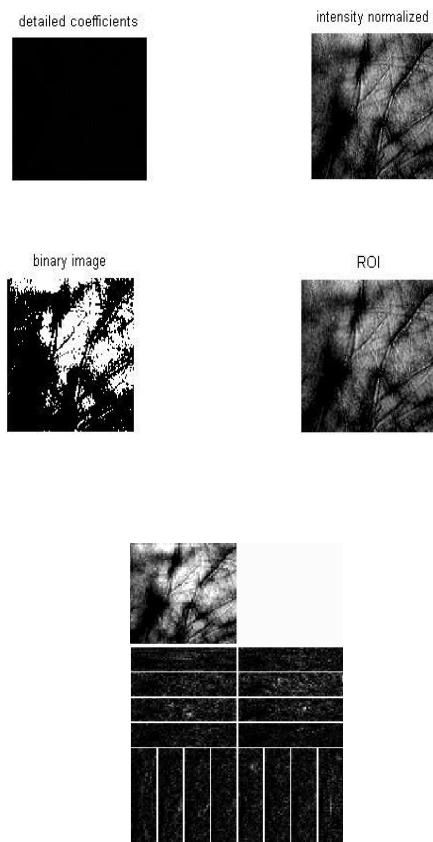

Fig 8 : Feature extraction by contourlet transform

5. CONCLUSION

In this paper, an efficient palmprint authentication system based on the fusion of multi-spectral palm images has been proposed. It uses wavelet decomposition for palm image fusion, contourlet transform for coefficients extraction for feature matching Genetic Algorithm is used. With this kind of feature selection approach it is expected to achieve a three-fold objective: improving the accuracy rate, providing faster and more cost-effective predictors because of a significant reduction of the number of features; and providing a better understanding of the underlying process that generated the data. The proposed method improves classification accuracy and impressive performance in noisy and clean conditions.

ACKNOWLEDGMENTS

I express deep gratitude to my guide, Asst Prof. Alphonse Devasia, for his invaluable support and guidance, which effectively contributed in successful completion of project.

6. REFERENCES

- [1] K.Shanmugapriya1, M.Karthika, Dr. S.Valarmathy, M.Arunkumar “Performance Evaluation of Contourlet Transform based Palmprint Recognition using Nearest Neighbour Classifier” International Journal of Emerging Technology and Advanced Engineering Website: www.ijetae.com (ISSN 2250-2459, ISO 9001:2008 Certified Journal, Volume 3, Issue 1, January 2013.
- [2] A. K. Jain, A. Ross & S. Prabhakar. (2004). An Introduction to Biometric Recognition, In: IEEE Transactions on Circuits and Systems for Video Technology, Vol. 14, N. 1, pp 4-20, January 2004.
- [3] W.K. Kong and D. Zhang, “Palmprint Texture Analysis based on Low-Resolution Images for Personal Authentication”, 16th International Conference on Pattern Recognition, Vol. 3, pp. 807-810, August 2002.
- [4] S.Valarmathy, M. A. Kumar, M. Sudha, “Improvement in palmprint recognition rate using fusion of multispectral palmprint images”, Proceedings of Int. Conf. on Computing Communication and Application (ICCCA), pp. 1-5, 2012.
- [5] Yan Jin1, Miao Qi,Yinghua Lu, Yao Fu, JunKong. Palmprint Verification Based on Genetic Algorithm Proceedings of 2008 3rd International Conference on Intelligent System and Knowledge Engineering.
- [6] Priyanka Somvanshi, Milind Rane “Survey of Palmprint Recognition” International Journal of Scientific & Engineering Research Volume 3, Issue 2, February-2012 1 ISSN 2229-5518.
- [7] David Zhang, Zhenhua Guo, Guangming Lu, Lei Zhang, and Wangmeng Zuo, “An Online System of Multispectral Palmprint Verification”, IEEE transactions on instrumentation and measurement, vol. 59, no. 2, February 2010, pp 480-490.
- [8] Minh N. Do, Member, IEEE, and Martin Vetterli Fellow, IEEE Transaction On Image Processing “The Contourlet Transform, an Efficient Directional Multiresolution Image Representation”.
- [9] Gayathri, R. and P. Ramamoorthy, “Palmprint Recognition using Feature Level Fusion”, Journal of Computer Science August 2012 ISSN 1549-3636.
- [10] ThePolyU Palmprint Database Available at <http://www.comp.polyu.edu.hk/~biometrics>