

Examine the impact of Modulation Order and Sub-bands on PAPR Reduction Techniques using Various Modulator in 802.11a/b/g

Gaurav Chandra
Dehradun Institute of
Technology
Dehradun (India)

Dinesh Kumar Saxena
Dehradun Institute of
Technology
Dehradun (India)

Anuj Saxena
Karnataka State University
Karnataka (India)

ABSTRACT

In the modern era of communication Orthogonal Frequency Division Multiplexing (OFDM) technique is the most widely used in wireless technology. With some advantage come few issues such as Peak to Average Power Ratio (PAPR) that leads High Power Amplifiers (HPA) to be worked in nonlinear region which causes inter-modulation distortion and out of band radiation. To overcome with this problem, several techniques were used. Whereas, this paper uses most efficient signal scrambling technique, Partial Transmit Sequence (PTS) and Selected Mapping (SLM) to be worked with various modulators such as Orthogonal Quadrature Phase Shift Key (OQPSK) and Quadrature Amplitude Modulator (QAM) and Binary Phase Shift Key (BPSK). Under different modulator and different parameters like Sub-Band, Modulation factor, these techniques were analyzed and compared.

Keywords

BPSK, OFDM, OQPSK, PAPR, PTS, QAM and SLM

1. INTRODUCTION

IN today's era of modernization where wireless communications are maturing day by day, orthogonal frequency division multiplexing technique has become the most significant assets which is used worldwide. It is pervasive from wireless local area network (802.11g), worldwide interoperability for microwave access (WIMAX), to the long term evolution (LTE) system, and digital video broadcasting (DVB-T, DVB-T2) [1]. The OFDM is a digital modulation technique that upholds high bit rate transmission so it is used in high speed video and audio communication with eradication of inter symbol interference (ISI) and inter channel interference (ICI). It can accommodate bountiful number of user and increase the spectral efficiency of the system. The orthogonal signals are required for favoring orthogonal frequency division multiplexing system. This concept is used to separately demodulate overlapping carriers. Orthogonality is a podium to expeditiously transmit information signals via a familiar channel without any interference. Lack of this Property may disgrace the communication. The OFDM modulation technique is used in 802.11g which is known as wireless (WLAN). One of the IEEE standards, 802.11 is a wireless networking transmission methods that is commonly used today in 802.11a, 802.11b,

802.11g and 802.11 versions to ease wireless connectivity with throughput to up to 54 mbit/s using the same 2.4 GHz band in various places or organization such as abode, office and commercial purpose [1]. With some of the vantage with OFDM system (which has many narrow band signals in the time domain) has one major issue that is its large peak-to-average power ratio which leads to cause inter-modulation distortion and out-of-band radiation due to nonlinear function of power amplifier. This amplifier must be work in its linear region to combat distortion, out-of-band noise and bit error rate degradation. Non-linearity leads to low spectral efficiency and high amount of dissipation of power which is limited for use in many wireless applications. This is the reason why PAPR must be reduced for application used in OFDM system. Therefore, in order to find a way so as to abase high PAPR effectively, it is prominent to reduce the PAPR of an OFDM signal. With previous years researchers has been working on various schemes giving an attempt to reduce the PAPR in orthogonal frequency division multiplexing (OFDM) system. These schemes can be further classified into two prominent types which are signal distortion and signal scrambling techniques. One of the common schemes include in Signal scrambling techniques are Selected mapping (SLM) scheme"[5],[6],[8]" and Partial transmit sequence (PTS) schemes"[3],[4],[7],[10],[12]". Among all these schemes, the SLM and PTS schemes have been considered the most efficiently schemes due to its high PAPR reduction performance without incurring additional signal distortion. The rest of this paper is organized as follows. Section II, manifest OFDM signal and PAPR formulation. Section III gives summary description of PAPR reduction techniques. Section VI shows simulated experimental results. Further, section V comes with the conclusion.

2. OFDM SIGNAL AND PAPR FORMULATION

In an OFDM system, the data block of N symbols, denoted by $X=[X_0, X_1, X_2, \dots, X_{N-1}]^T$, is modulated by a set of orthogonal sub-carrier, f_k , $\{k=0, 1, 2, N-1\}$, where T denotes the transpose. In OFDM system to sustain the orthogonality of the signals, the spacing Δf between neighboring subcarriers is set to be a multiple of $1/T$. i.e., $\Delta f=1/T$, where T is the duration of an OFDM symbol and m is a positive integer we set m to be the least positive integer, in order to make full use of the

bandwidth; then the transmitted OFDM symbol is given by [3].

$$x(t) = \frac{1}{\sqrt{N}} \sum_{k=0}^{N-1} X_k e^{j2\pi f_k t}, \quad 0 \leq t \leq T \quad (1)$$

The OFDM signal are transform by a number of independent sub carriers, which introduce the high peak to average power (PAPR) when these sub carriers are combined constructively. The various frequency signal produces a high peak power when added up in a same phase. Generally, the PAPR of the OFDM signal is known as the ratio of the maximum power to its average power of the signal.

$$PAPR = 10 \log_{10} \frac{\max_{0 \leq t \leq T} |x(t)|^2}{P_{av}} \quad (2)$$

Where P_{av} is the average power of the signals in time domain, and $x(t)^2$ is the maximum peak of the signal [1].

3. SIGNAL SCRAMBLING TECHNIQUES

In the signal scrambling techniques, the input message blocks are encoded by multiply the phase sequence vector to reduce the PAPR efficiently without introducing the distortion. The encoded message can easily be decoded by the help of same phase vector sequence, although the signal become complex but it maintains the bit error rate. There are two signal scrambling techniques are dissected in this paper namely Partial Transmit Sequence and Selected Mapping [6].

3.1 Selected Mapping Technique (SLM)

In Selected Mapping Technique (SLM), input data is divided into sub data blocks of having length N given below.

$$X = [X_0, X_1, X_3, \dots, X_{N-1}] \quad (3)$$

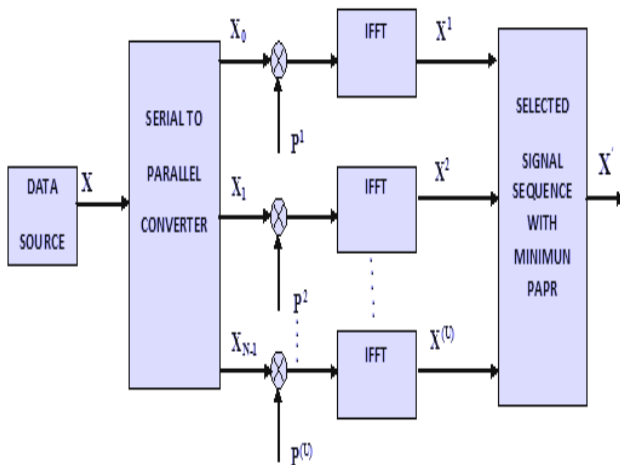

Fig. 1: Block diagram of the SLM scheme

Then it is converted into the parallel data stream using serial to parallel converter. When the data is parallel converted then OFDM data block is multiplied element by element with Phase sequence given as

$$P^u = [P^1, P^2, P^3, \dots, P^U] \quad (4)$$

By using $u = [0, 1, 2, \dots, U]$ make OFDM data block to be phase rotated.

Therefore $X^{(u)}$ expressed as,

$$\begin{aligned} X^{(U)} &= [X_0^{(U)}, X_1^{(U)}, X_2^{(U)}, \dots, X_{N-1}^{(U)}]^T \\ &= [P_0^{(U)} X_0, P_1^{(U)} X_1, \dots, P_{N-1}^{(U)} X_{N-1}]^T \\ &= P^{(U)} X \end{aligned} \quad (5)$$

As we phase rotated data blocks, the rotated OFDM data blocks represents similar information which are unmodified OFDM data blocks, provided with known phase sequence. In Fig. 1 block diagram of the SLM technique is shown. In this frequency domain signal is converted into the time domain $X^{(u)}$, by the help of IFFT. The signal comes from IFFT block is in time domain having the lowest PAPR value and same information as the original OFDM signal. The OFDM signal having lowest PAPR value in decibel would be selected for making high power amplifier (HPA) worked in the linear region. The actual signal is recovered by the help of side information at the receiving end. The side information is the knowledge about the phase sequence used at the transmitting end to reduce the PAPR. The two main draw backs of SLM technique are, first is the side information and another is the phase sequence. For improving PAPR performance there is a need of increasing the number of phase sequence which increases the complexity of the system. As the number of phase sequence increased the size of side information is also increased proportionally as a result spectral efficiency decrease. These disadvantages are overcome by using other technique called Partial Transmit Sequence.” [1], [2]”

3.2 Partial Transmit Sequence (PTS)

In the partial Transmit sequence (PTS), the transmitted data block is divided in small parts before applying to the IFFT block, the small data sub-blocks are multiplied by the weighted Phase vector and the resultant data block have the minimum PAPR value as compared to the input data block, the small divided data block is given by the equation.

$$X_m = [X^0, X^1, X^2, \dots, X^{v-1}]^T \quad (6)$$

Where $v = [1, 2, 3, \dots, V]$, Then, the IFFT block is required to convert the frequency domain sub-blocks (X_m) in the time domain sub-blocks (x_m), given by the equation.

$$x_m = \sum_{v=1}^V IFFT(X_m) \quad (7)$$

After that, the time domain data sub-blocks is multiplied by the weighted phase vector ‘P’ which is given as,

$$P = [P_1, P_2, \dots, P_m] \quad (8)$$

Now the divided data sub-block and phase factor are required to combined together to create a set of candidates which having the lowest value of PAPR in decibel.

$$X' = \sum_{m=1}^M P_m x_m \quad (9)$$

The block diagram of the partial transmit sequence (PTS) is shown in the given below Fig.2. The objective is to optimally combine the ‘V’ sub-blocks to obtain the time domain OFDM signals with the lowest PAPR[1], [2], [3]”.

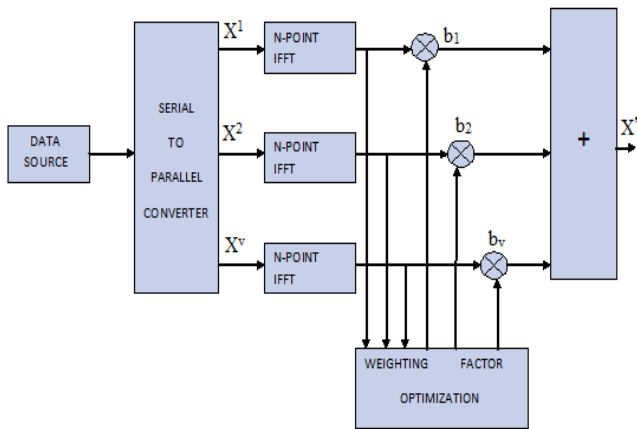

Fig. 2: Block diagram of partial transmit sequence scheme.

4. Simulated Experimental Results

In this section, firstly the graphical user interface (GUI) is created in matlab simulation tool and then writes the code under each button to calculate the PAPR values. There are two way to take a input data firstly the recorded voice or secondly to load the save voice file. The performance evaluation and comparison of PTS & SLM PAPR reduction technique by using different modulator OQPSK, QAM and BPSK has been done. The various parameter used in simulation, namely transmitted data, PAPR reduction technique, modulator, modulator Order ‘M’ and sub-band ‘SB’ is listed in the table 1.

TABLE 1 Simulation Parameter

| Simulation Parameter | |
|--------------------------|-------------------------|
| Transmitted Data | 70400 |
| PAPR Reduction Technique | PTS & SLM |
| Modulator Used | QAM , OQPSK & BPSK |
| Modulation Order ‘M’ | QAM=2,4,8,16,32,64,128 |
| | BPSK=2,4,8,16,32,64,128 |
| | OQPSK=4 only |
| Sub-band ‘SB’ | 64,128,256,512 |

In Fig.3 the comparison of PTS, SLM and the original OFDM signal by using OQPSK modulator has been shown. It is resulted that the PTS schemes perform the better performance as compared to SLM and original OFDM signal at the parameter are listed in the TABLE 2.

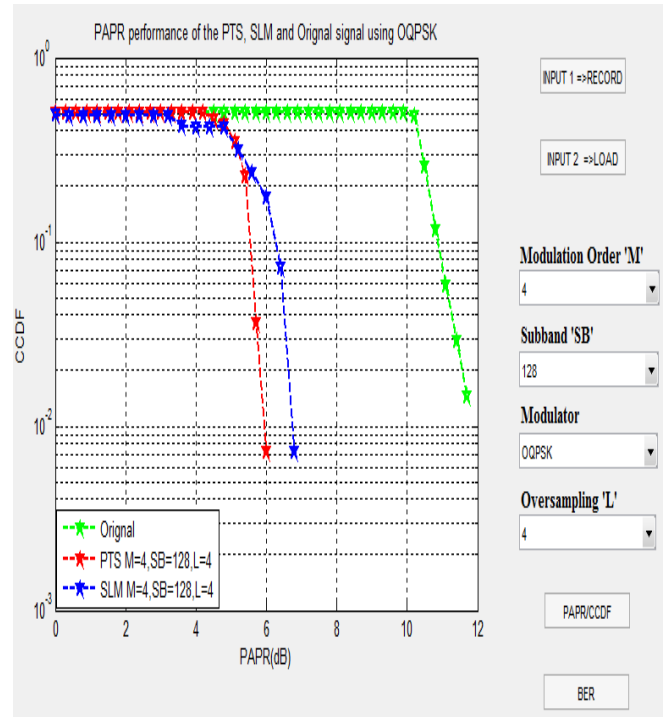

Fig. 3: CCDF/PAPR curve of Original, SLM & PTS schemes, while using QAM modulator.

The TABLE 2 Shown below listed the PAPR values of the different PAPR reduction technique and original OFDM signal at the different parameter.

TABLE 2 PAPR values comparison at different parameter using OQPSK

| PAPR Performance Comparison In PTS,SLM & Original Signal Using OQPSK | | | | |
|--|----------------------|-------------------------|---------------|------------|
| Technique Used | Modulation Order ‘M’ | Oversampling Factor ‘L’ | Sub-band “SB” | PAPR In db |
| PTS | 4 | 4 | 128 | 6.00 |
| SLM | 4 | 4 | 128 | 7.04 |
| Original signal | 4 | 4 | 128 | 11.78 |

In the next experiment, the QAM modulator is used to compare the PTS and SLM PAPR reduction Technique. Similar result is seen as the OQPSK modulator shown. The PTS is performing superior result over the SLM and the original OFDM signal. The main difference is observed that the QAM reduces the better PAPR value as compared to the OQPSK value in the PTS scheme.

The PAPR vs. CCDF curve shown in Fig.4 demonstrates the comparison result of PTS, SLM and original OFDM signal.

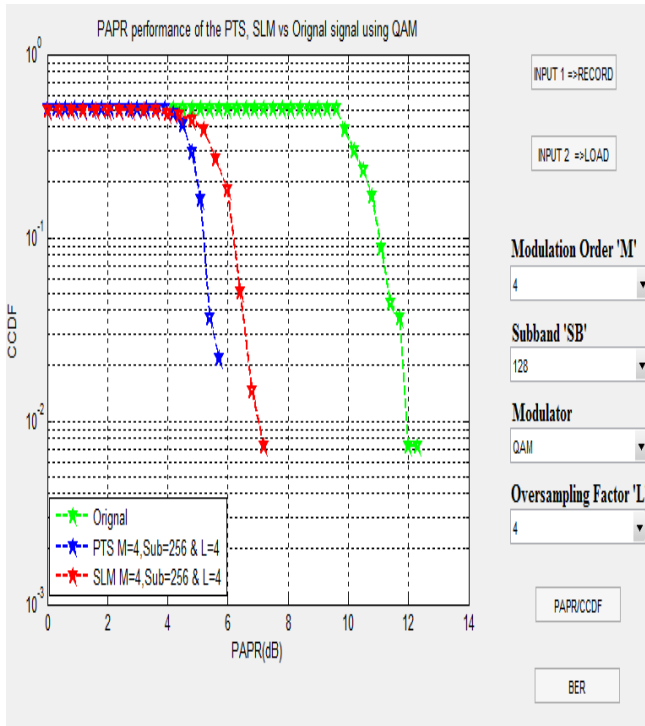

Fig. 4: CCDF/PAPR curve of Original, SLM & PTS schemes, while using QAM modulator.

As shown in the Table 3 given below, out of the three techniques used for the comparison of PAPR, PTS shows the best performance among the three using QAM. The PAPR values and the parameters used in this experiment are listed in the table.

TABLE 3 PAPR values comparison at different parameter using QAM

| PAPR Performance Comparison In PTS,SLM & Original Signal Using QAM | | | | |
|--|----------------------|-------------------------|---------------|------------|
| Technique Used | Modulation Order 'M' | Oversampling Factor 'L' | Sub-band "SB" | PAPR In db |
| PTS | 4 | 4 | 128 | 5.82 |
| SLM | 4 | 4 | 128 | 7.31 |
| Original signal | 4 | 4 | 128 | 12.41 |

In the next experiment, the effect of sub-bands is analyzed on PAPR values while using QAM modulator. Here PTS technique is used while varying the Sub-band and keeping all the parameter constant namely modulation Order 'M' and the oversampling factor 'L' shown in the Fig 5. As shown in the TABLE 4 given below, the PAPR performance of PTS using QAM modulator is analyzed at different sub-bands.

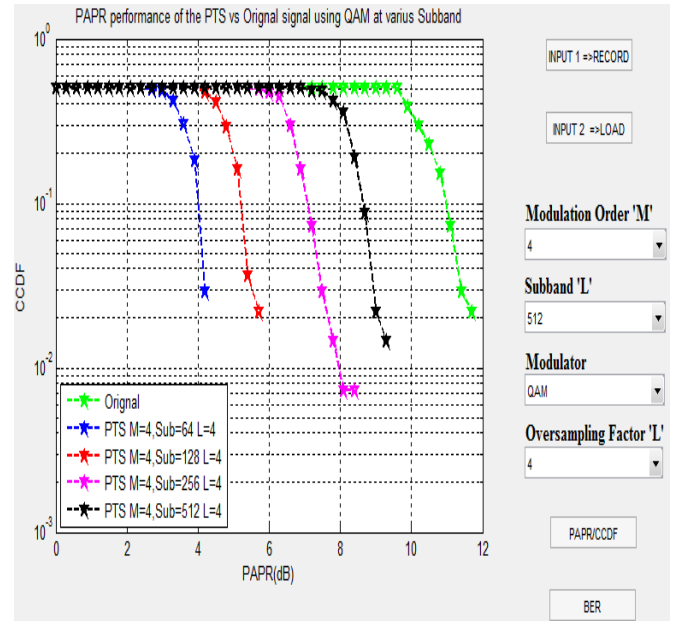

Fig. 5: CCDF/PAPR curve of Original & PTS schemes, while using QAM modulator at various sub-bands.

According to that as we increased the number of sub-bands PAPR is increasing simultaneously.

TABLE 4 PAPR values at different sub-bands using QAM

| PAPR Performance Of PTS Using QAM At Different Sub-bands 'SB' | |
|---|------------|
| Sub-band 'SB' | PAPR in db |
| 64 | 4.42 |
| 128 | 5.78 |
| 256 | 8.51 |
| 512 | 9.34 |

Now in the next experiment, the same experiment is performed through SLM Scheme using OQPSK modulator by keeping the entire parameters constant and varying the sub-band (SB).The PAPR vs. CCDF curve shown in the Fig. 6 demonstrates that SLM perform better as compared to original OFDM signal and the PAPR in increasing with increasing number of sub-bands.

TABLE 5 PAPR values at different sub-bands using OQPSK

| PAPR Performance Of SLM Using OQPSK at Different Sub-bands 'SB' | |
|---|------------|
| Sub-band 'SB' | PAPR in db |
| 32 | 6.00 |
| 64 | 6.81 |
| 128 | 6.41 |
| 256 | 6.91 |
| 512 | 8.00 |

The different value of PAPR at different sub-bands ‘SB’ is shown in the TABLE 5 and it is analyzed that the PAPR is increasing simultaneously as the number of sub-bands is increased.

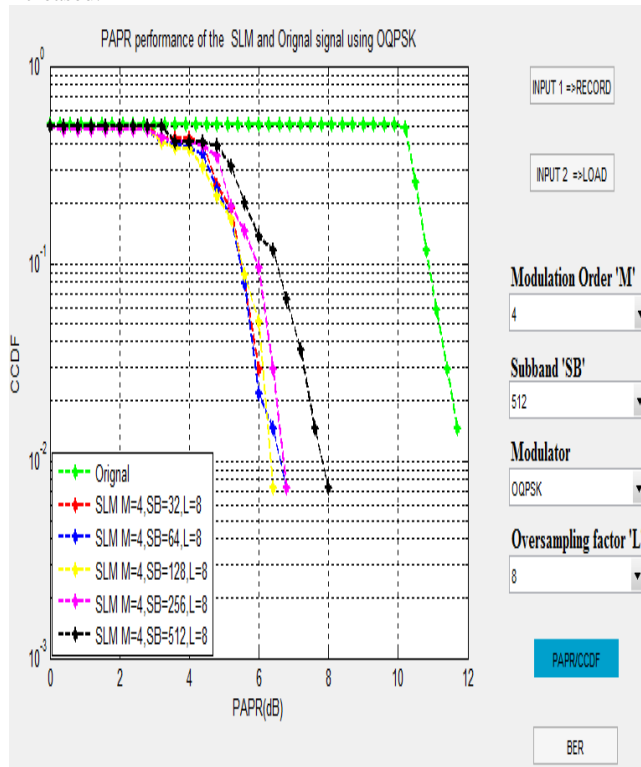

Fig. 6: CCDF vs. PAPR curve of Original, SLM schemes, while using OQPSK modulator at various sub-bands.

Now the next experiment is performed by using the Binary Phase shift Key Modulator (BPSK) again the PTS technique perform the better PAPR reduction as compared to other techniques, the only thing is observed that the PAPR values in BPSK is slightly higher as compared with the other two modulator. The CCDF vs. PAPR curve shown in the Fig.7 demonstrate the comparison between the PTS, SLM and the original signal.

TABLE 6 PAPR values comparison at different parameter using BPSK

| TABLE 6 PAPR Performance Comparison In PTS,SLM & Original Signal Using BPSK | | | | |
|--|----------------------|-------------------------|---------------|------------|
| Technique Used | Modulation Order 'M' | Oversampling Factor 'L' | Sub-band "SB" | PAPR In db |
| PTS | 2 | 4 | 64 | 6.03 |
| SLM | 2 | 4 | 64 | 7.10 |
| Original signal | 2 | 4 | 64 | 11.80 |

The TABLE 6 shows the PAPR values of the PTS, SLM and the Original OFDM signal. It is shows that the PAPR value of PTS is lower among the other two schemes SLM and original OFDM signal at modulation order ‘M’ sub-band ‘SB’ and Oversampling factor ‘L’ by using BPSK modulator.

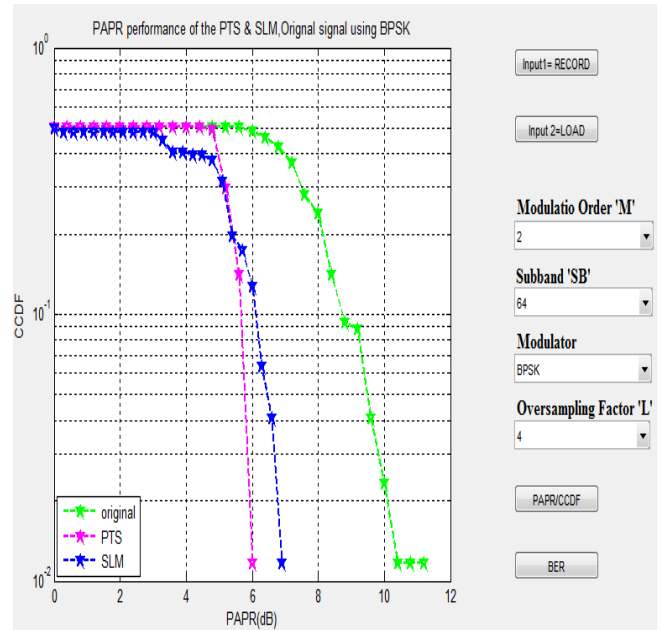

Fig. 7: CCDF vs. PAPR curve of PTS, SLM and Original while using BPSK modulator.

In the next experimental setup the BPSK modulator is used and the value of PAPR is analyzed while varying the sub-band ‘SB’ and keeping the other parameters constant. The value of PAPR is increased as we increased the sub-band ‘SB’. The variation in the PAPR values is shown in the Fig.8

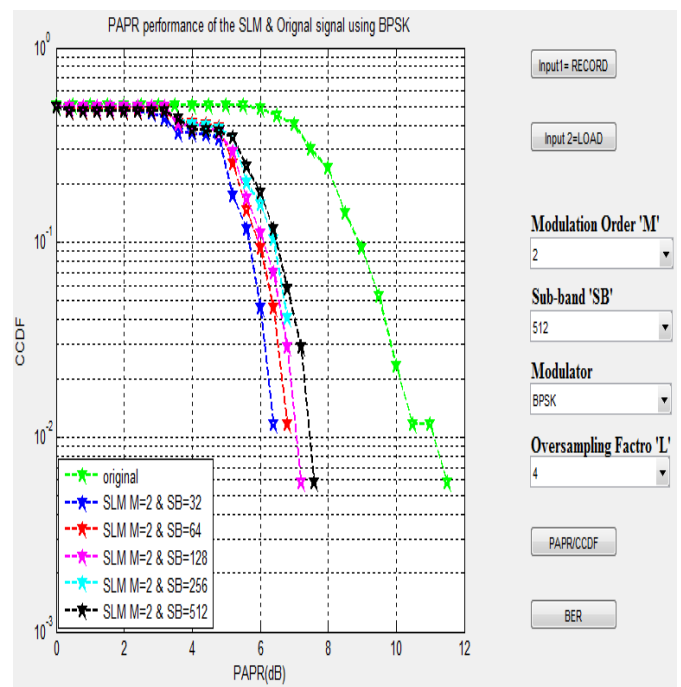

Fig. 8: CCDF vs. PAPR curve of Original, SLM schemes, while using BPSK modulator at various sub-bands.

The TABLE 7 shown below listed the different PAPR values at different sub-bands using SLM PAPR reduction technique in BPSK modulator. At sub-band 32 it shows lowest PAPR value that is 6.37db and the highest PAPR value of 7.83 at sub-band 512.

TABLE 7 PAPR values at different sub-bands‘SB’ using BPSK

| Sub-band ‘SB’ | PAPR in db |
|---------------|------------|
| 32 | 6.37 |
| 64 | 6.91 |
| 128 | 7.38 |
| 256 | 7.41 |
| 512 | 7.82 |

In the next experiment, the effect of modulation order is analyzed on the PAPR value using SLM technique in BPSK modulator. Here the modulation order ‘M’ is varying and all the other parameters are kept constant namely sub-band ‘SB=128’ and oversampling factor ‘L=4’. It was observed that when modulation order is increased the value of the PAPR is also increased simultaneously. The CCDF vs. PAPR curve using SLM technique in BPSK modulator is shown in Fig.9.

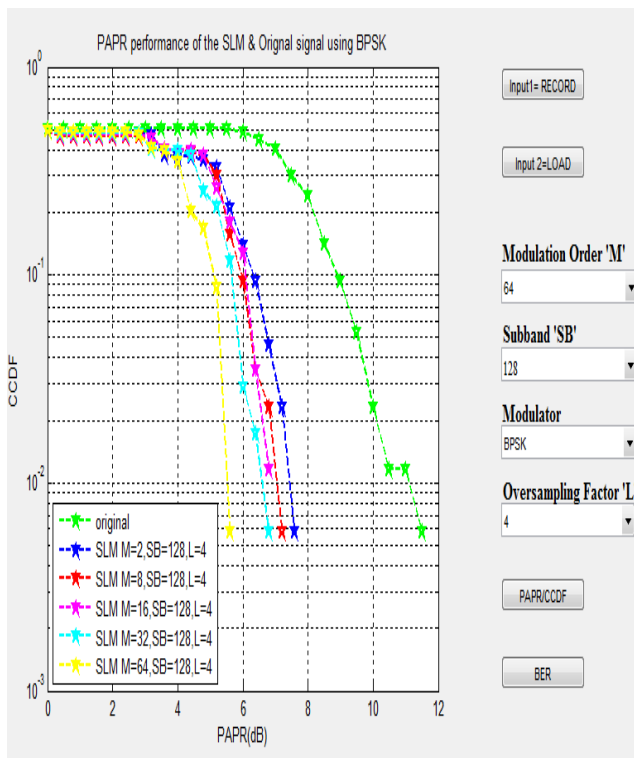

Fig. 9: CCDF vs. PAPR curve of Original, SLM schemes, while using BPSK modulator at various Modulation order.

The value of PAPR in decibel at various modulation order ‘M’ is listed in the TABLE 8 given below, from the table it is easily analyzed that as the modulation order is increased the value of PAPR is decreased step by step. At the highest modulation order ‘M=64’ the value of PAPR is 5.83 db and for the lowest modulation order ‘M=2’ it is 7.77db.

TABLE 8 PAPR values at different Modulation order ‘M’ using BPSK

| Modulation Order ‘M’ | PAPR In db |
|----------------------|------------|
| 2 | 7.77 |
| 8 | 7.36 |
| 16 | 7.03 |
| 32 | 6.92 |
| 64 | 5.83 |

In the final experiment, the bit error rate is calculated between the transmitted and the PTS signal because it is very important to preserve the bit error rate of the signal while reducing the PAPR. It is found that the bit error rate is almost the same so it is proved that the PTS reduces the PAPR efficiently without degrading the bit error rate shown in Fig.10.

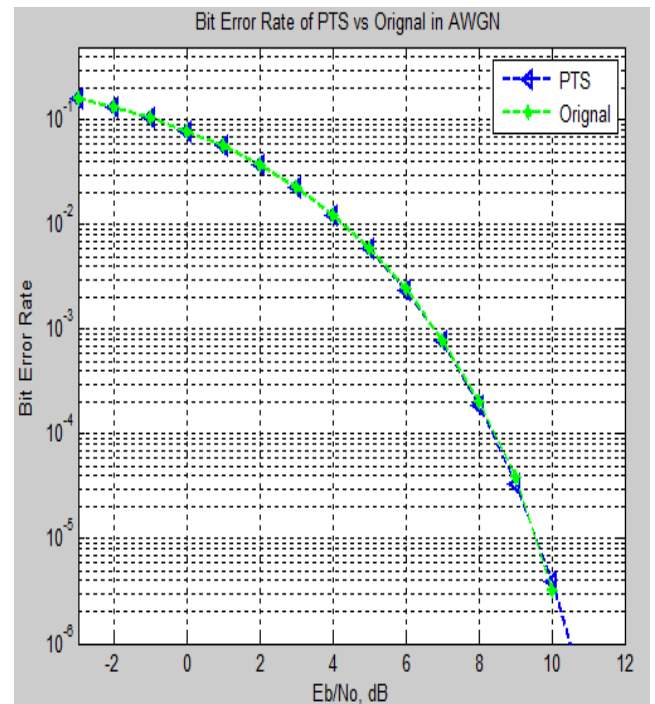

Fig. 10: BER curve of PTS & Original transmitted signal, while using QAM modulator.

The similar experiment is also done in the SLM scheme by using the BPSK modulator and it also give the same result as the PTS schemes that is the bit error rate is almost equal to the original transmitted signal in case of SLM slight increased in Es/No value shown in Fig.11.

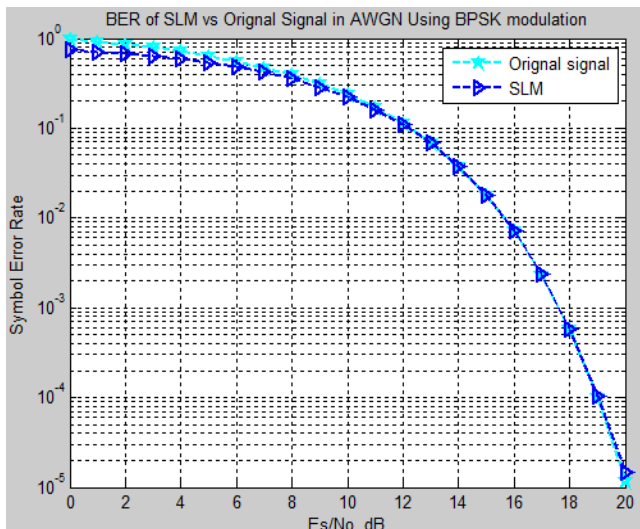

Fig. 11: BER curve of SLM & Original transmitted signal, while using BPSK modulator.

5. CONCLUSION

In this paper, the two very efficient PAPR reduction scheme PTS and SLM are used under three modulator namely QAM, OQPSK and BPSK by varying different parameter in WLAN. The PTS scheme performs much better than SLM in PAPR reduction technique, the graph and the tables supports the statement. The three modulators are used in the experiment out of which the QAM is performing better than PAPR reduction in comparison with OQPSK & BPSK. The sub-bands play a very important role, as the number of sub-bands is increased the PAPR is increased simultaneously because the number of IFFT operation is increased proportionally. The variation in PAPR values is greater in QAM as compared to OQPSK and BPSK by varying sub-bands shown in Fig.5, 6 & 8. The modulation order 'M' is also very important parameter, as the modulation order is increased the PAPR value starts decreasing step by step shown in Fig.9. Finally the bit error rate comparison has shown in Fig.10 between the original transmitted signal and the PTS shows that the PTS reduces PAPR very effectively without degrading the bit error rate. Similarly, Fig. 11 shows that the SLM technique reduces the PAPR efficiently while keeping almost the same bit error rate to original transmitted signal.

6. REFERENCES

- [1] C. Nade, P. N. Landin, W. V. Moer, N. Bjorsell, and P.Hande, "Performance Evaluation of Peak-to-Average-Power-Ratio Reduction and Digital Pre Distortion for OFDM Based System" IEEE Trans. on Microwave Theory and Techniques vol. 59, no. 12, Dec. 2011.
- [2] M. Deumal, C. Vilella, J. L. Pijoan, and P. Bergadà, "Partially Clipping (PC) Method for the Peak-to-Average Power Ratio (PAPR) Reduction in OFDM", IEEE Int. Symposium on Personal Indoor and Mobile Radio Communications, vol.1, Sept. 2004.
- [3] J. Hou, J. Ge, and J. Li, "Peak-to-Average Ratio Reduction of OFDM Signal Using PTS Scheme With Low Computational Complexity ", IEEE Trans. on Broadcasting, vol. 57, no. 1, Mar.2011.
- [4] S.Eom, H. Nam, Y.C. Ko "Low Complexity PAPR Reduction Scheme without Side information For OFDM Systems" IEEE Trans. on Signal Processing, vol. 60, no. 7, Jul.2012.
- [5] V. Cuteanu, A. Isar " PAPR Reduction of OFDM Signals Using Selective Mapping and Clipping Hybrid Scheme", 20th European Signal Processing Conference (EUSIPCO 2012) , Bucharest, Romania, Aug. 27 - 31, 2012.
- [6] K. A. Mahajan, S. V. Mukhare, "Comparison of Signal Scrambling PAPR Reduction Techniques with Signal Distortion Techniques in OFDM Signal", International Conference on Recent Trends in Information Technology and Computer Science (IRCTITCS) 2011 Proceedings published in International Journal of Computer Applications® (IJCA).
- [7] M.V.R.Vittal, "Performance enhancement of OFDM signals using PAPR reduction Techniques and the Comparison of their Performance", International Journal of Computer Applications (0975 – 8887) Volume 41– No.19, March 2012.
- [8] S. Cho and S. K. Park, "A New Selected Scheme without Additional IFFT Operation in OFDM Systems" IEEE Trans. on Consumer Electronics, vol. 57, no. 4, Nov. 2011.
- [9] Md. I. Abdullah, Md. Z. Mahmud, Md. S. Hossain, Md. N. Islam "Comparative Study of PAPR Reduction Techniques in OFDM", ARPN Journal of Systems and Software, vol. 1, no. 8, Nov. 2011.
- [10] J. Armstrong, "New Peak-to-Average Power Reduction scheme", Proc.of IEEE Vehicular Technology, May 2001.
- [11] L. Yang, K. K. Soo, S. Q. Li, and Y. M. Siu, "PAPR Reduction Using Low Complexity PTS to Construct of OFDM Signals Without Side Information" IEEE Trans. on Broadcasting, vol. 57, no. 2, Jun.2011.

