

Bank Locker Security System based on RFID and GSM Technology

R.Ramani
Assistant Professor / ECE
V.M.K.V Engineering College,
Salem, tamilnadu, India

S. Selvaraju
Professor / ECE
V.M.K.V Engineering College,
Salem, tamilnadu, India

S.Valarmathy
Associate Professor / ECE
V.M.K.V Engineering College,
Salem, tamilnadu, India

P.Nirajan
Design Engineer
Tatva Software
Bangalore

ABSTRACT

The main goal of this paper is to design and implement a bank locker security system based on RFID and GSM technology which can be organized in bank, secured offices and homes. In this system only authentic person can be recovered money from bank locker. We have implemented a bank locker security system based on RFID and GSM technology containing door locking system using RFID and GSM which can activate, authenticate, and validate the user and unlock the door in real time for bank locker secure access. The main advantage of using passive RFID and GSM is more secure than other systems. This system consists of microcontroller, RFID reader, GSM modem, keyboard, and LCD, in this system The RFID reader reads the id number from passive tag and send to the microcontroller, if the id number is valid then microcontroller send the SMS request to the authenticated person mobile number, for the original password to open the bank locker, if the person send the password to the microcontroller, which will verify the passwords entered by the key board and received from authenticated mobile phone. if these two passwords are matched the locker will be opened otherwise it will be remain in locked position, This system is more secure than other systems because two passwords required for verification. This system also creates a log containing check-in and check-out of each user along with basic information of user.

Keywords: GSM.RFID, locking system, Keyboard, Microcontroller

1. INTRODUCTION

In this present age, safety has becomes an essential issue for most of the people especially in the rural and urban areas. Some people will try to cheat or steal the property which may endanger the safety of money in the bank, house, and office. To overcome the security threat, a most of people will install bunch of locks or alarm system. There are many types of alarm systems available in the market which utilizes different types of sensor. The sensor can detect different types of changes occur in the surrounding and the changes will be processed to be given out a alert according to the pre-set value. By the same time this system may not be good for all the time. In this paper we have implemented safety of the money in the bank locker, house, and office (treasury) by using RFID and GSM technology which will be more secure than other systems. Radio-frequency identification (RFID)

based access-control system allows only authorized persons to open the bank locker with GSM technology. Basically, an RFID system consists of an antenna or coil, a transceiver (with decoder) and a transponder (RF tag) electronically programmed with unique information. There are many different types of RFID systems in the market. These are categorized on the basis of their frequency ranges. Some of the most commonly used RFID kits are low-frequency (30-500 kHz), mid-frequency (900 kHz-1500MHz) and high-frequency (2.4-2.5GHz)[1]. The passive tags are lighter and less expensive than the active tags [2]. Global system for mobile communication (GSM) is a globally accepted standard for digital cellular communication. GSM is a common European mobile telephone standard for a mobile cellular radio system operating at 900 MHz In the current work, SIM300 GSM module is used. The SIM300 module is a Triband GSM/GPRS solution in a compact plug in module featuring an industry-standard interface. It delivers voice, data and fax in a small form factor with low power consumption. [3].in this paper we have designed and implemented a bank locker security system based on RFID and GSM technology. In this system only authentic person can be recovered moneyfrom bank locker with two password protection method.

2. RELATED WORKS

In this section some related works connected to the monitoring system using GSM services.

In [4] has developed a Prepaid Water Meter System for prepaid billing of water consumption through remote monitoring without any human involvement. This system may be fast and accurate billing of water as well as preventing any mishandling of it. However, [5] developed a water meter reading using GSM system that suitable for remote places to monitor the water meter reading before any billing process. This could reduce the use of human resource for reading the meter and issuing a bill. There was also a work on monitoring of electrical meter reading using GSM network done by [6]. The system was able of monitoring the meter reading and sent an SMS to the official center for billing purpose. This could reduce the number of estimated reading when the empower person unable to reach the meter.

In [7], this system is used to control home appliance tenuously and offer security when the owner is away from the place. The similar work presented in [8] which designed and developed a

smart home application system. The system allows the property owner to be able to monitor and control the residence appliances via a mobile phone set by sending commands in the form of SMS messages and receiving the home appliances status

In [9], one more approach using GSM technology to communicate with the remote devices via SMS is remote metering system, in this paper illustrates a technique for remotely reading electricity meter readings using SMS. Both postpaid and prepaid are feasible to implement using this architecture as SMS based data gathering can be done very quickly and efficiently.

In [10] [11], this paper projected a Zigbee-GSM based Monitoring and Remote Control System. In this systems used both Zigbee and GSM for communicating between user and devices. This system allows user to monitor and control devices in the home through a number of controls, including a Zigbee based remote control. Users may remotely monitor and control their home devices using GSM.

In [12], the most important objective of the paper is to design and develop a highly developed vehicle locking system in the real time situation. The design & development of a theft control system for an automobile, which is being used to prevent/control the theft of a vehicle. This system consists of an embedded system and Global System Mobile communication (GSM) technology. This system developed by Pravada P. Wan hade and Prof. S.O. Dahad, the developed system is installed in the vehicle. The mobile is connected to the microcontroller, which is in turn, connected to the engine. Once, the vehicle is being stolen, the information is being used by the vehicle owner for further processing. The information is passed onto the central processing insurance system which is in the form of the SMS, the microcontroller unit reads the SMS and sends it to the Global Positioning System (GPS) module and says to lock it or to stop the engine immediately. The main concept of this paper vehicle is controlled by GSM and GPS. The designed unit is reliable and efficient system for providing security to the vehicles through GSM, GPS and serial communication.

3. PROPOSED METHOD

In this proposed work, the RFID reader reads the data from tag and send to the microcontroller, if the card is valid then microcontroller display the account holder name and number.

Then the account holder need to enter the password, if the password is valid then microcontroller sends the SMS to account holder mobile number. Then account holder sends the password to the microcontroller through mobile phone using GSM. The microcontroller compares the passwords entered by keyboard and received through mobile phone. If these passwords are correct the microcontroller provides necessary control signal to open the bank locker. This method is simple and more secure than other system.

3.1 RFID Fundamentals

Basically, an RFID system consists of an antenna or coil, a transceiver (with decoder) and a transponder (RF tag) electronically programmed with unique information. There are many different types of RFID systems in the market. These are categorized on the basis of their frequency ranges. Some of the most commonly used RFID kits are low-frequency (30-500 kHz), mid-frequency (900 kHz-1500MHz) and high-frequency (2.4-2.5GHz). Basically, an RFID system consists of three components: an antenna or coil, a transceiver (with decoder) and a transponder (RF tag) electronically programmed with unique information. An RFID reader is a device that is used to interrogate an RFID tag. The reader has an antenna that emits radio waves; the tag responds by sending back its data. An RFID tag is a microchip combined with an antenna in a compact package; the packaging is structured to allow the RFID tag to be attached to an object to be tracked. "RFID" stands for Radio Frequency Identification. The tag's antenna picks up signals from an RFID reader or scanner and then returns the signal, usually with some additional data (like a unique serial number or other customized information). A passive tag is an RFID tag that does not contain a battery; the power is supplied by the reader. When radio waves from the reader are encountered by a passive RFID tag, the coiled antenna within the tag forms a magnetic field. The tag draws power from it, energizing the circuits in the tag. The tag then sends the information encoded in the tag's memory. The RX and TX pins of RFID reader connected to Tx and Rx pins of AT89C51 Microcontroller respectively. Then the reader senses the data from the Tag and transmits the sensed data to microcontroller via serial port.



Figure1. RFID Reader

3.2 GSM modem SIM300 V7.03

The GSM modem is a specialized type of modem which accepts a SIM card operates on a subscriber's mobile number over a network, just like a cellular phone. Basically, it is a cell phone without display. modem sim300 is a tri-band GSM/GPRS engine that works on EGSM900MHz,DCS1800MHz and PCS1900MHz frequencies.GSM Modem is RS232-logic level compatible, i.e., it takes-3v to -15v as logic high and +3v to +15 as logic low.MAX232 is used to convert TTL into RS232 logic level converter used between the microcontroller and the GSM board. The signal at pin 11 of the microcontroller is sent to the GSM modem through pin 11 of max232.this signal is received

at pin2 (RX) of the GSM modem. The GSM modem transmits the signal from pin3 (TX) to the microcontroller through MAX232, which is received at pin 10 of IC1.

Features of GSM

- Single supply voltage 3.2v-4.5v
- Typical power consumption in SLEEP Mode: 2.5mA.
- SIM300 tri-band
- MT,MO,CB, text and PDU mode, SMS storage: SIM card
- Supported SIM Card :1.8V,3V



Figure2. GSM modem

4. Block diagram

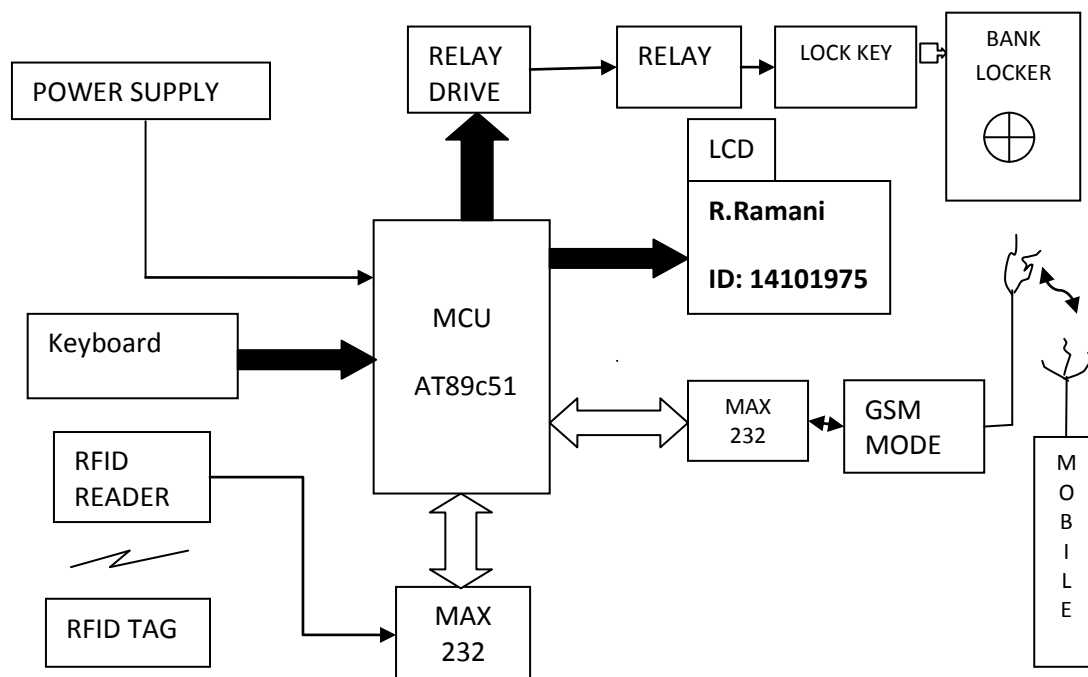

Figure3. Block diagram of Bank locker system based on RFID and GSM technology

The block diagram of Bank locker system based on RFID and GSM technology is shown in the figure3. It comprises the power supply section, keyboard, RFID Reader, AT89C51 microcontroller, MAX232driver, relay driver and GSM

modem, LCD. The GSM board has a valid SIM card with sufficient recharge amount to make outgoing calls. The circuit is powered by regulated +5v dc.

5. CIRCUIT DESCRIPTION

5.1 Power supply

The power supply section is the important for any electronics circuits. To derive the power supply, the 230V, 50Hz AC mains is stepped down by transformer X1 to deliver a

secondary output of 12V, 500 mA. The transformer output is rectified by a full-wave rectifier comprising diodes D1 through D4, filtered by capacitor C1 and regulated by ICs 7812 (IC2) and 7805 (IC3). Capacitor C2 bypasses the ripples present in the regulated supply. LED1 acts as the power indicator and R1 limits the current through LED1. The power supply section is shown in the figure4.

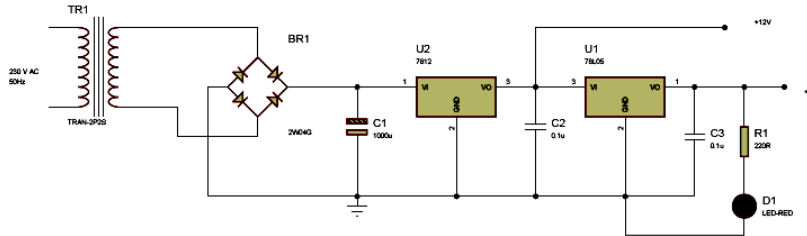

Figure4. Power supply

5.2 Circuit diagram

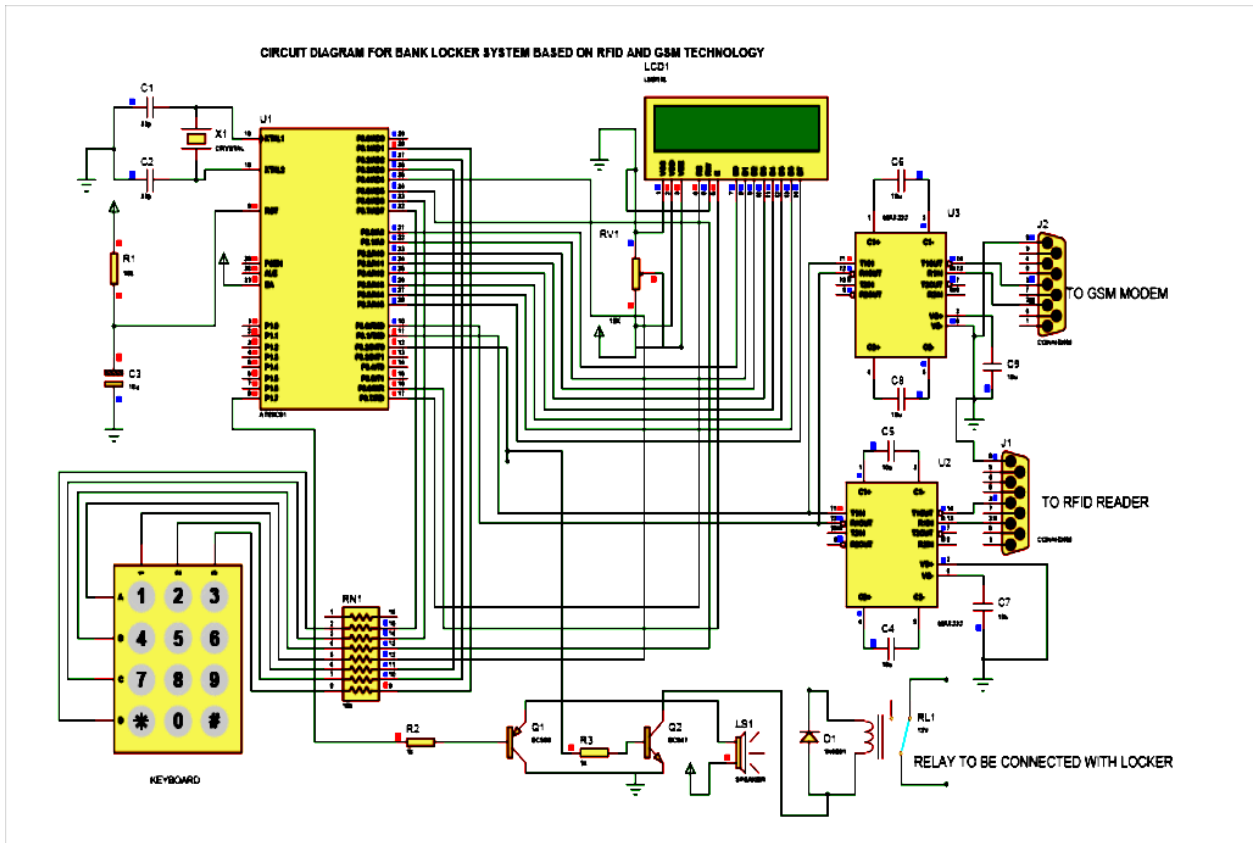

Figure5. Circuit diagram of Bank locker system based on RFID and GSM technology

Fig.5 shows the circuit of the Bank locker system based on RFID and GSM technology. The compact circuitry is built around Atmel AT89C52 microcontroller. The AT89C52 is a low-power; high performance CMOS 8-bit microcomputer with 8 kB of Flash programmable and erasable read only memory (PEROM). It has 256 bytes of RAM, 32 input/output (I/O) lines, three 16-bit timers/ counters, a six-vector two-level interrupt architecture, a full-duplex serial port, an on-chip oscillator and clock circuitry. The system clock also plays a significant role in operation of the microcontroller. An 11.0592MHz quartz crystal connected to pins 18 and 19 provides basic clock to the microcontroller. Power-on reset is provided by the combination of electrolytic capacitor C3 and resistor R1. Port pins P2.0 through P2.7 of the microcontroller are connected to data port pins D0 through D7 of the LCD, respectively. Port pins P3.7 and P3.6 of the microcontroller are connected to register-select (RS) and enable (E) pins of the LCD, respectively. Read/write R/W pin of the LCD is grounded to enable for write operation. All the data is sent to the LCD in ASCII format for display. Only the commands are sent in hex form. Register-select (RS) signal is used to distinguish between data (RS=1) and command (RS=0). Preset RV1 is used to control the contrast of the LCD. Resistor 10k limits the current through the backlight of the LCD. Port pins P3.0 (RXD) and P3.1 (TXD) of the microcontroller are used to interface with the RFID reader through Max232(1) and GSM Modem are used to interface through Max232(2). When an allowed person having the tag enters the RF field generated by the RFID reader, RF signal is generated by the RFID reader to transmit energy to the tag and retrieve data from the tag. Then the RFID reader communicates through RXD and TXD pins of the microcontroller for further processing. Thus on identifying the authorized person, the authorized person enters the password through keyboard and send to the microcontroller. If the password is correct then the microcontroller send the SMS to the account holder person, account holder again send the password through SMS to the microcontroller. The microcontroller verifies the password and received password through GSM mobile. If this password is correct, the microcontroller provides high signal to port pin P3.2, transistor Q2 drives into saturation, and relay RL1 energizes to open the bank locker. Simultaneously, the LCD shows "access granted" message and send to and port pin P1.7 drives piezo buzzer PZ1 via transistor T1 for aural indication. If the password is not valid, the LCD shows "access denied" and the bank locker doesn't open.

6. SOFTWARE PROGRAM TESTING

The software program is written in c or assembly language and compiled using keil software. After compiler operation the hex code is generated and stored in the computer. The hex code of the program is burnt into the AT89C51 by using Top win Universal programmer.

6.1 Hardware Assembling and Testing:

First step, we need to make single side PCB layout of the Bank locker system based on RFID and GSM technology for testing the circuit, proceed as follow

1. After assembling all the components on the PCB, connect TX and RX pins of the GSM modem to pins 13 and 14 of MAX 232 and RFID Reader, respectively and insert a valid SIM in the card holder of the GSM modem.
2. Connect ground pins of the GSM modem and RFID to the ground rail of the circuit.

3. This projects are implemented and tested successfully by us.
4. This system is very useful for bank locker, office, homes to keep the money safely.

6.2 Comparative study of existing and proposed locker system

S.No	Existing system	Proposed system
1	RFID Technologies used	Rfid and GSM Technologies used
2	One password is referred	Two password are referred
3	May be in Secured due to robbery of RFID and password	More secured due to double password

7. CONCLUSIONS

We have implemented a Bank locker security system using passive RFID and GSM. It is a low cost, low in power conception, compact in size and standalone system. The microcontroller compares the passwords entered by keyboard and received through mobile phone. If these passwords are correct the microcontroller provides necessary control signal to open the bank locker. Alarm will be turn on whenever door is forced to open. Future work of this paper, is planned to a develop security system based on 3G camera for visual identification of the person.

8. REFERENCES

- [1]. Parvathy A, Venkata Rohit Raj, Venumadhav, Manikanta, "RFID Based Exam Hall Maintenance System", IJCA Special Issue on "Artificial Intelligence Techniques - Novel Approaches & Practical Applications" AIT, 2011
- [2]. Gyanendra K Verma, Pawan Tripathi, "A Digital Security System with Door Lock System Using RFID Technology", International Journal of Computer Applications (IJCA) (0975 – 8887), Volume 5– No.11, August 2010
- [3]. Kumar Chaturvedula .U.P, "RFID Based Embedded System for Vehicle Tracking and Prevention of Road Accidents", International Journal of Engineering Research & Technology (IJERT) , Vol. 1 Issue 6, August – 2012, ISSN: 2278-0181
- [4]. Islam, N.S. Wasi-ur-Rahman, M. "An intelligent SMS-based remote Water Metering System". 12th International Conference on Computers and Information Technology, 2009, 21-23 Dec. 2009, Dhaka, Bangladesh.
- [5]. Mohd Helmy Abd Wahab, Siti Zarina Mohd Muji, Fazliza Md. Nazir. "Integrated Billing System through GSM Network". In Proceeding of 3rd International Conference on Robotics, Vision, Information and Signal Processing 2007 (ROVISP2007), Penang, 28 – 30 November 2007
- [6]. Mohd Helmy Abd Wahab, Azhar Ismail, Ayob Johari and Herdawatie Abdul Kadir. "SMS-Based Electrical Meter Reading". In Proceeding of International

Conference on Rural Information and Communication Technology 2009 (r-ICT), 17 – 18 June 2009, Bandung, Indonesia

- [7]. Malik Sikandar Hayat Khiyal, Aihab Khan, and Erum Shehzadi, “ SMS Based Wireless Home Appliance Control System (HACS) for Automating Appliances and Security”, *Issues in Informing Science and Information Technology*. Vol. 9. pp. 887 – 894. 2009.
- [8]. Al-Ali, A.R. Rousan, M.A. Mohandes, M. “GSM-Based Wireless Home Appliances Monitoring & Control System”, *Proceedings of International Conference on Information and Communication Technologies: From Theory to Applications*, pp 237-238, 2004.
- [9] Md. Wasi-ur-Rahman, Mohammad Tanvir Rahman, Tareq Hasan Khan and S.M. Lutful Kabir, “Design of an Intelligent SMS based Remote Metering System”, Proceedings of the IEEE International Conference on Information and Automation, 2009, pp. 1040-1043.
- [10] Carelin Felix and I. Jacob Raglend, “Home Automation Using GSM”, Proceedings of 2011 International Conference on Signal Processing, Communication, Computing and Networking Technologies, pp. 15-19, 2011.
- [11] Ahmad A.W., Jan N., Iqbal S. and Lee C., “ Implementation of ZigBee-GSM based home security monitoring and remote control system”, IEEE 54th International Midwest Symposium on Circuits and Systems (MWSCAS), 2011, pp. 1-4.
- [12] Pravada P. Wankhade1 and Prof. S.O. Dahad2, “Real Time Vehicle Locking and Tracking System using GSM and GPS Technology-An Anti-theft System”, *International Journal of Technology And Engineering System(IJTES)*:Jan –March 2011- Vol.2.No.3.