

# A Hybrid Approach of Image Fusion using Modified DTCWT with High Boost Filter Technique

Vinay Sahu

Department of Computer Science Engineering  
Shri Satya Sai College Of Engineering  
Bhopal M.P.

Gagan Sharma

Department of Computer Science Engineering  
Shri Satya Sai College Of Engineering  
Bhopal M.P.

## ABSTRACT

To achieve improve quality of image two or more images are combined using a well known process, that process is called image fusion. The fused images provide us more information than the source images. Fusion process absolutely utilizes more entirely and surplus information. This paperproposes a hybrid approach using DTCWT with High boost filtering technique and the simulation of the proposed method is done in MATLAB2012a toolbox. The analysis of our method is performing among performance measuring parameter such MSE and PSNR in which analyze that our methodology gives improved results than the existing methods.

**Keywords:** HIS, PCA, Image fusion, Wavelet transform. MATLAB

## 1. INTRODUCTION

Image fusion is a process to blend multi-sensor images by using image processing techniques. Inexplicit image fusion means at integrating divergent and complementary data in order to augment the information perceptible in the images, as well as to enhance the dependability of the elucidation. This leads to more precise data and increased efficacy. Moreover, it is also acknowledged that the fused data endow with vigorous operational performance such as increased dependability, reduced vagueness, improved assurance and better classification. Image fusion is a method that endeavors at the integration of incongruent and corresponding data to augment the dependability of the elucidation. This method leads to additional precise data explanation and efficacy [1].

The fusion process is nothing but a permutation of prominent information in order to amalgamate an image with further information than individual illustration and amalgamated image is more appropriate for visual perception. It is used to denote a process by which manifold images or information from manifold images is pooled. These images may be achieved from unusual types of sensors. By means of the accessibility of the multi-sensor data in numerous fields, such as satellite imaging, remote sensing, medical imaging or machine visualization, image fusion has materialized as promising and significant investigation vicinity. On the other hand, image fusion is a practice of uniting various input images of the identical prospect into a particular fused image, which safeguards whole content information and also preserving the imperative attributes from all of the original images. The fused image must have additional valuable information content compared to the individual image. This method is classified into two categories: spatial domain and transform domain fusion. The images can be fused by different fusion techniques such as IHS (intensity hue saturation), PCA (principle component analysis) based fusion and transform based image fusion in which high pass filtering, pyramid and wavelet transform method is included. The HIS and PCA

method belongs to spatial domain techniques while DWT and DCT comes into transform based fusion. The spatial domain techniques add up the distortion with the images. The transform based fusion is a powerful tool to fuse multisensory images. The performance of the image fusion techniques is analyzed using different parameter likewise PSNR (peak signal to noise ratio), entropy, MSE.

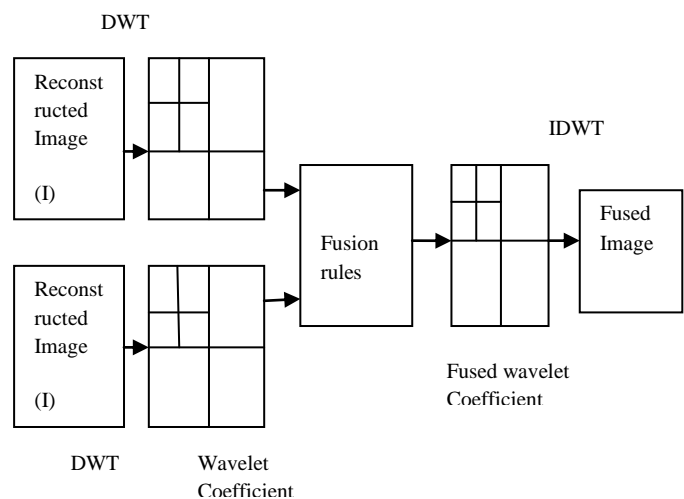

Fig. 1 Block diagram for image fusion process

The organization of the remaining section of the paper is as follows: Next section II describes the overview of the image fusion techniques. Section III presents the review of the previously work done in area of image fusion. In section IV describe our proposed methodology and section V shows the experimental analysis of the proposed method. Last section gives overall conclusion of the paper and its future scope.

## 2. IMAGE FUSION TECHNIQUES

The image fusion is basically classified in two categories namely: spatial domain and transform based fusion techniques. The spatial domain techniques includes following method like IHS, PCA and brovey method while transform fusion includes: high pass filtering, pyramid and wavelet transform. In this section some techniques of image fusion are describing below:

### 2.1 Spatial domain method

The spatial domain method [2], directly deals with the pixels of the input images. The pixel values are operate to achieve most wanted result. The example of spatial domain techniques is select maximum/ minimum fusion, HIS, PCA and brovey etc.

#### a) Select maximum/ minimum Method:

In this method [3], the consequential fused image is achieved by selecting the maximum intensity of subsequent pixels from both the input image.

$$F(i, j) = \sum_{i=0}^m \sum_{j=0}^n \text{Max}A(i, j)B(i, j) \dots \dots \dots (1)$$

A(i, j), B(i, j) are input images and F(i, j) is fused image.

**b) Select Minimum Method:**

In this method [3], the resulting fused image is attained by selecting the smallest intensity of resulting pixels from both the input image.

$$F(i, j) = \sum_{i=0}^m \sum_{j=0}^n \text{Min}A(i, j)B(i, j) \dots \dots \dots (2)$$

A(i, j), B(i, j) are input images and F(i, j) is fused image.

**c) IHS (Intensity Hue Saturation):**

The IHS method is one of the most regularly used fusion method for sharpening. It has become a standard process in image investigation for color enhancement, feature enhancement, enhancement of spatial resolution and the fusion of incongruent data sets [4]. Here the IHS space, spectral information is typically reflected on the hue and the saturation. As of the visual system, one can ends that the intensity modifies has modest consequence on the spectral information and is uncomplicated to deal with. For the synthesis of the high-resolution and multi-spectral remote sensing images, the principle is ensuring the spectral dataset and adding the additional information of high spatial resolution, consequently, the fusion is even more satisfactory for treatment in IHS space [5].

**d) Brovey Method:**

Brovey Transform is also known as the color normalization transform as it entails a red-green-blue (RGB) color transform method. It is statistical/numerical methods. Brovey Transform uses addition, division and multiplication for the fusion of three multispectral bands. The Brovey Transform was developed to visually enhance contrast in the small and high ends of an images histogram (i.e., to supply contrast in shadows, water, and high reflectance areas such as urban features). The Brovey transformation was developed to circumvent the disadvantages of the multiplicative method. The subsequent equation shows the mathematical algorithm for the Brovey method [9].

$$F_i = \frac{M_i}{\sum_{i=1}^N M_j + P} \dots \dots \dots (3)$$

Where Fi is the fused Band, Mi is the multispectral Band, P is the Panchromatic Band.

**e) Principal Component Analysis (PCA)**

PCA is a statistical tool which transforms a number of correlated variables into a number of uncorrelated variables. The PCA is used comprehensively in image compression and image classification. The PCA entails a mathematical process that transforms a number of correlated variables into a number of uncorrelated variables called principal components. It works out a squashed and optimal explanation of the data set. The first principal component accounts for as much of the variance in the data as probable and every succeeding component accounts for as much of the remaining variance as possible. Foremost principal component is taken to be alongside the direction with the maximum variance. The subsequent principal component is constrained to lie in the subspace perpendicular of the foremost. Surrounded by this subspace, this component points the direction of maximum variance. The third principal component is taken in the maximum variance direction in the subspace vertical to the initial two and so on. The PCA is also called as

Karhunen-Loève transform or the Hotelling transform. The PCA does not have a fixed set of basis vectors like FFT, DCT and wavelet etc. and its origin vectors depend on the data set [11].

**2.2 Transform Based Fusion**

The transform based fusion is an important tool to combine two or more image to obtain more supplementary information. In Transform domain fusion method image is initial transformed into frequency domain. Some of them transform based fusion is enlightened below:

**a) Discrete Wavelet Transform**

Wavelet theory is a conservatory of Fourier theory in many phases and it is introduced as an unconventional to the short-time Fourier transform (STFT). In this, the signal is decomposed into sines and cosines however in wavelets the signal is anticipated on a set of wavelet functions. Fourier transform would supply good resolution in frequency domain and wavelet would make available good resolution in both time and frequency domains. Even though the wavelet theory was introduced as a mathematical tool in 1980s, it has been comprehensively used in image processing that supplies a multi-resolution decomposition of an image in a bi-orthogonal basis and results in a non-redundant image demonstration. The basis is called wavelets and these are functions generated by transformation and dilation of mother wavelet. In Fourier analysis the signal is decomposed into sine waves of diverse frequencies. In wavelet analysis the signal is decomposed into scaled (dilated or lengthened) and shifted (transformed) versions of the preferred mother wavelet or function. A wavelet as its name involves is a small wave that cultivates and decays fundamentally in a limited time period. A wavelet to be a small wave, it has to satisfy two basic properties [2]:

- Time integral must be zero

$$\int_{-\infty}^{\infty} \varphi(t) dt = 0 \dots \dots \dots (4)$$

- Square of wavelet integrated over time is unity

$$\int_{-\infty}^{\infty} \varphi^2(t) dt = 1 \dots \dots \dots (5)$$

Wavelet transform of a 1-D signal f (x) onto a basis of wavelet functions is defined as:

$$W_{a,b}(f(x)) = \int_{-\infty}^{\infty} f(x)\varphi_{a,b}(x)dx = 0 \dots \dots \dots (6)$$

**3. RELATED WORK**

In this section, describing some of the previously work done for fusing the multiple images to extract the more essential information by various researchers.

Kim et al. [8] initiated a new-fangled method based on the curvelet transform which represents edges better than wavelets. Since edges play an elementary role in image understanding, one good way to develop spatial resolution is to augment the edges. Curvelet-based image fusion method presents more affluent information in the spatial and spectral domains simultaneously. They performed IKONOS image fusion. This novel method has accomplished an optimum fusion result.

Rana et al. [9] explored unusual medical image fusion methods and their comparison to discover out which fusion method gives better results based on the performance parameters. Here

medical images of Magnetic Resonance Imaging (MRI) and Computed Tomography (CT) images are fused to form fresh image. This novel fused image progresses the information content for diagnosis. Fusing MRI and CT images present more information to doctors and clinical treatment planning system. MRI presents improved information on soft tissues whereas CT presents improved information on denser tissues. Fusing these two images bestows more information than single input image. In this, wavelet transform, Principle Component Analysis (PCA) and Fuzzy Logic techniques are utilized for fusing these two images and outcomes are compared. Singh et al. [10] proposed a fresh detail-enhancing revelation fusion method using non-linear translation-variant filter (NTF). Due to the captured Standard Dynamic Range (SDR) images under unusual exposure settings, primary the excellent details are extracted based on guided filter. Subsequently, the base layers (i.e., images obtained from NTF) transversely all input images are fused using multi-resolution pyramid. Exposure, dissimilarity, and saturation measures are considered to engender a mask that guides the fusion process of the base layers. In conclusion, the fused base layer is combined with the digger out fine details to achieve detail-enhanced fused image. The purpose is to safeguard details in both tremendously dark and extremely bright regions without High Dynamic Range Image (HDRI) representation and tone mapping step. Furthermore, they had demonstrated that the proposed method is also appropriate for the multifocus image fusion exclusive of introducing artifacts.

Mini et al. [11] proposed an augmentation technique which exploits Stationary Wavelet Transform (SWT), modulus maxima and high boost filtering. The image is decomposed using SWT and its modulus maximum is indomitable. A division of the high pass filtered image achieved as the result of SWT decomposition and modulus maxima is supplementary to original image. The system is evaluated visually and dispassionately using measures like dissimilarity, PSNR etc. The performance measures are appraised for dissimilar class of images and found to be appropriate to all categories of mammographic images.

Tsagariset al. [12] proposed a method for hyper-spectral image fusion based on principal components transformation (PCT). The foremost principal component of every subgroup is used for image visualization. The number of bands in all sub-groups depends on the application. On the other hand, in their work, three sub-groups were used for RGB representation. One of the sub-groups employed matched filtering based on the spectral characteristics. The excellence of the obtained RGB images were quantitatively estimated using parameters like, correlation coefficient, entropy, and the maximum energy-minimum correlation index. The performance of their technique in categorization has been tested using the K-means algorithm.

#### 4. PROPOSED WORK

In this section we are describing our work to extract the essential features by fusing the multiple images from image dataset. In our work DTCWT and Filtering techniques is used to fuse the images.

##### 4.1 DT-CWT (Dual Tree Complex Wavelet Transform)

In the dual tree complex wavelet transform method, [13] the fusion is performed using masquerades to dig out information from decomposed structure of DT-CWT [13]. The DT-CWT arrangement engages both the real and complex coefficients.

This complex transform employs two detach DWT decompositions. It is divided into two detach trees, tree A and tree B as revealed in figure 2 below.

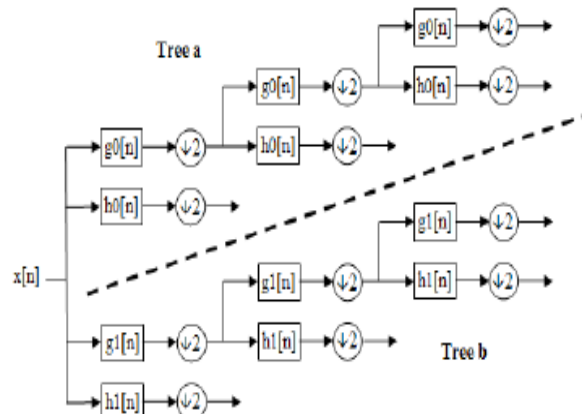

Fig.2 Structure of DT-CWT

The fusion progression absorbs the formation of the fused pyramid using DT-CWT coefficients which are achieved from the decomposed pyramids of the input source images. The fused image is fashioned by applying inverse DT-CWT transform. DT-CWT preserves the restrained texture regions of brain in MRI images. Ringing outcomes are reduced and edge details are also retained more obviously. This DT-CWT is more beneficial than the DWT method as it is directional sensitivity and shift variant in behavior.

##### 4.2 Fusion Rule:

Entropy is the determination of information content in the image. A high value of entropy represents more information content and vice versa. Consequently this statistical determination could be used in making a decision to choose the fusion coefficient [14].

$$H(S) = - \sum P(X) \log p(X) \dots \dots \dots (7)$$

Entropy is premeditated on the low frequency components of the input images surrounded by a 3-by-3 window and either having higher values of entropy were selected or the fusion coefficients among the low frequency components. Subsequently the coefficient is selected as the fuse coefficient when the region energy of it is better shown as formula

$$F_p^k(i, j) = \begin{cases} A_p^k(i, j), & \text{if } A_p^{km}(i, j) > B_p^{km}(i, j) \\ B_p^k(i, j) & \text{Otherwise} \end{cases} \quad (8)$$

In conclusion the fused image is reconstructed using the fused coefficients  $F_p^k(i, j)$  using the inverse NSCT transform.

**4.3 High pass filters:** A high pass filter is mostly used for sharpening purpose. When an image is sharpened and contrast is superior between bordering areas with little variation in brightness or low eminence information.

$$\text{High pass} = f(x, y) - \text{low pass} \dots \dots \dots (9)$$

**4.3.1 High-boost Filtering:** A high-boost filter is also identified as a high-frequency prominence filter. A high-boost filter is used to preserve several of the low-frequency apparatus to abet in the elucidation of an image. In high-boost filtering

input image  $h(m, n)$  is multiplied by an amplification factor  $A$  prior to subtracting the low-pass image. Accordingly, the high-boost filter expression is:

$$High\ Boost = A * f(m, n) - low\ pass \dots \dots \dots (10)$$

Adding and subtracting 1 with gain factor, then  
High boost =  $(A-1) * f(x, y) + f(x, y) - low\ pass$   
So

$$High\ Boost = (A - 1) * f(x, y) + High\ pass \dots \dots \dots (11)$$

#### 4.4 Proposed Algorithm

1. Select Image A from database
2. Select Image B from database
3. Apply DTCWT and decomposed images into sub-bands(LL, LH, HL, HH)
4. Wavelet coefficient into A and B
5. Apply transform function on A, B
6. Apply high pass filter into decomposed layers of A and B
7. Apply Gaussian filter to removes extra noise from decomposed layers
8. Then apply high boost filter to improve intensity of each decomposed layers
9. Apply fusion rule:

$$F_p^k(i, j) \begin{cases} A_p^k(i, j), & \text{if } A_p^{km}(i, j) > B_p^{km}(i, j) \\ B_p^k(i, j) & \text{Otherwise} \end{cases}$$

10. Then fused all improved wavelet coefficients
11. Apply INV-DTCWT function
12. Now Compute MSE is as follows:

$$MSE = \frac{1}{mn} \sum_{i=1}^m \sum_{j=1}^n (A_{ij} - B_{ij})^2$$

13. And compute PSNR as follows:

$$PSNR = 10 \times \log_{10} \left( \frac{peak^2}{MSE} \right)$$

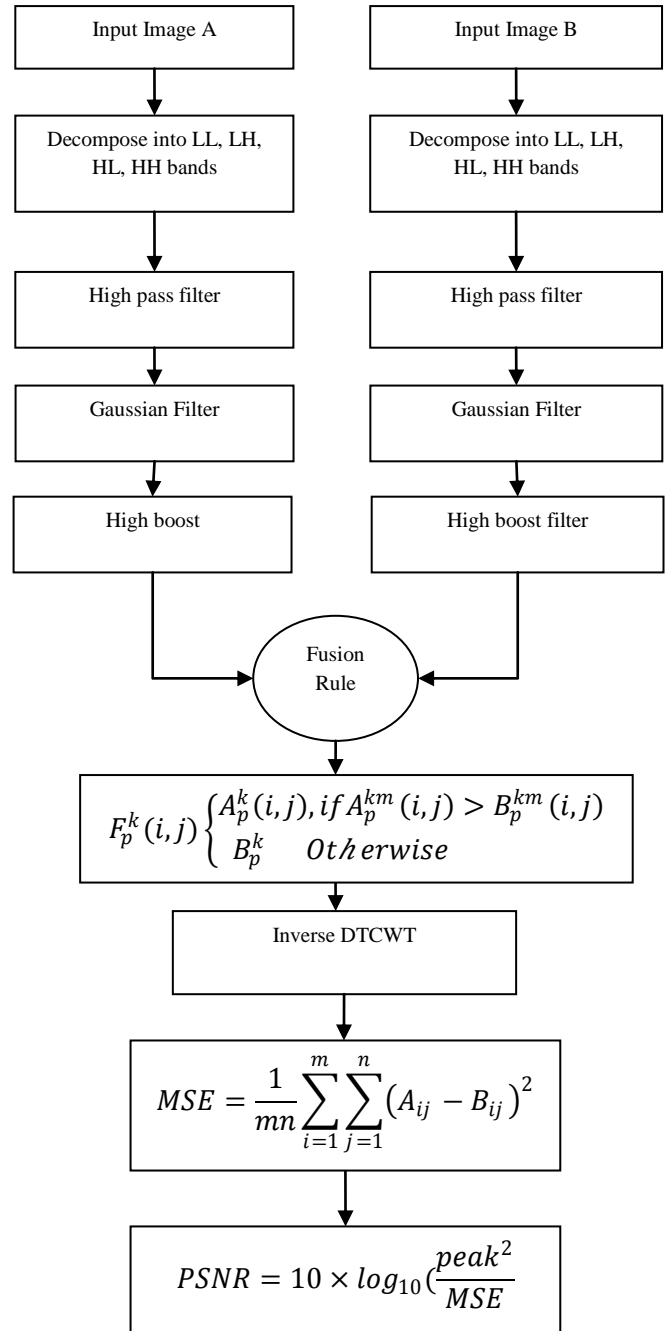

Fig. 3 Block diagram for proposed methodology

Here block structure of proposed methodology shows that initially, we have taken the input of two images from the dataset and then decomposes it in the form LL, LH, HL, HH sub bands by applying DT-CWT technique. Later then, apply high pass filter into decomposed layer of input image A and B. Again introduce Gaussian filter to sharp or eliminating the extra noise from the decomposed layer. After applying Gaussian filter apply High Boost filter to improve the intensity of each decomposed layers. Then apply fusion rule to blend the decomposed layer and finally apply inverse DT-CWT to get the fused image with more information.

## 5. EXPERIMENTAL RESULTS

In this section, we show the implementation and analysis of our proposed work and the implementation is done using the C++ programming language. The simulation of our work is done using the well known MATLAB2012a [15]. The analysis is done among different image dataset and comparison done by PSNR and MSE. From this analysis, observe that our proposed methodology give better results than the DWT and DTCWT image fusion technique. For comparing the methods, they have tested four repudiated images set namely: Saras, clock, balloon and leopard. And here Fig. 4, fig. 5 show the main GUI environment of implemented system which contains the all compared method and illustrate the result after successful completion, here they observed that the MSE is less at most time and PSNR is higher of proposed method as compared with DWT and DTCWT.



Fig. 4 GUI environment for saras.jpg

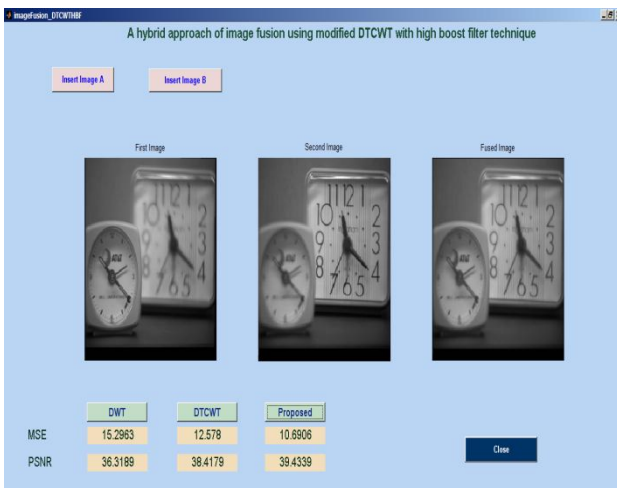

Fig. 5 Clock fused image dataset

Here table 1 and table 2 shows the comparison of the proposed method among DWT and DTCWT in which observe that simulation result is much better for MSE and PSNR performance parameter and it is illustrated through chart.

Table 1 MSE comparison of proposed method

MSE comparison			
Method/image	DWT	DTCWT	Proposed
saras.jpg	18.4819	16.3807	12.0408
clock.png	15.2963	12.578	10.6906

baloon.png	9.00496	7.16232	11.8188
lapord.png	18.133	14.7277	12.8613

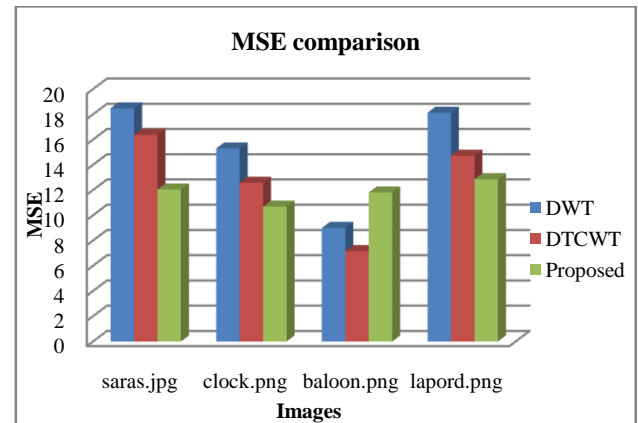

Fig. 6 MSE comparison of DWT, DTCWT and proposed method

Table 2 PSNR comparison of all methods

PSNR comparison			
Method/image	DWT	DTCWT	Proposed
saras.jpg	41.5179	43.4862	45.4631
Clock.png	36.3189	38.4179	39.4339
baloon.png	39.3088	41.6777	39.7112
leopard.png	36.2689	38.4216	39.309

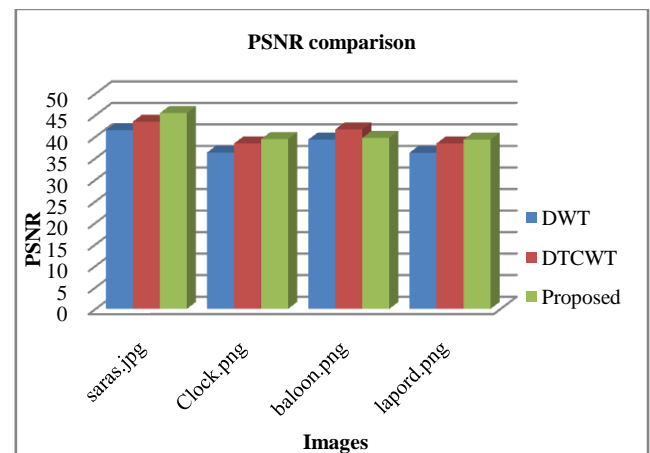

Fig. 6 PSNR comparison of DWT, DTCWT and proposed method

## 6. CONCLUSION

From the single image it is not possible to extract the essential or more information so to obtain more information the multiple images are fused together. Various techniques have been developed to fuse the images. In this paper, hybrid approach using DTCWT with high boost filtering is proposes. The analysis of this work is done using MSE and PSNR measuring parameter and the simulation results of proposed method gives better results than the existing methods. In future work, analyze this methodology among more performance measuring parameter except PSNR and MSE.

## 7. REFERENCES

- [1] S. Anbumozhi, P.S. Manoharan, "Performance Analysis of Fusion Based Brain Image Classification Using Minimum Distance classifier", *Journal of Theoretical and Applied Information Technology* 20 April 2014. Vol. 62 No.2, ISSN: 1992-8645.
- [2] C. Morris & R. S. Rajesh, "Survey of Spatial Domain Image fusion Techniques", *International Journal of Advanced Research in Computer Science Engineering and Information Technology* Volume: 2 Issue: 3 08-Apr-2014, ISSN NO: 2321-3337.
- [3] Kusum Rani, Reecha Sharma, "Study of Different Image fusion Algorithm", *International Journal of Emerging Technology and Advanced Engineering*. Website: [www.ijetae.com](http://www.ijetae.com) (ISSN 2250-2459, ISO 9001:2008 Certified Journal, Volume 3, Issue 5, May 2013).
- [4] Pohl C. and Van Genderen J. L., "Multi-sensor Image Fusion In Remote Sensing: Concepts, Methods And Applications", *International Journal Of Remote Sensing* 1998, Vol. 19, No.5, pp. 823-854.
- [5] Hui Y. X. and Cheng J. L., 2008. "Fusion Algorithm for Remote Sensing Images Based on Non sub sampled Contour-let Transform", *ACTA AUTOMATICA SINICA*, Vol. 34, No. 3, pp. 274- 281.
- [6] Sunil Kumar Panjeta and Deepak Sharma "A Survey on Image fusion Techniques used to Improve Image Quality", *International Journal of Applied Engineering Research*, ISSN 0973-4562 Vol.7 No.11, 2012.
- [7] V.P.S. Naidu and J.R. Raol, "Pixel-level Image Fusion using Wavelets and Principal Component Analysis". *Defense Science Journal*, Vol. 58, No. 3, May 2008, pp. 338-352 Ó 2008, DESIDOC.
- [8] MyungjinChoi , Rae Young Kim, Moon-Gyu Kim, "The Curvelet Transform For Image Fusion".
- [9] Rana, A. and S. Arora, "Comparative analysis of medical image fusion". *International Journal Computer Application* 2013, 73:10-13. DOI: 10.5120/12768-9371.
- [10] Harbinder Singh Vinay Kumar and Sunil Bhooshan, "A Novel Approach for Detail-Enhanced Exposure Fusion Using Guided Filter", *Hindawi Publishing Corporation the Scientific World Journal* Volume 2014, Article ID 659217.
- [11] Arya Devi P. S. and M. G. Mini, "Mammographic Image Enhancement Based on SWT and High Boost Filtering", *International Journal of Computer Theory and Engineering*, Vol. 7, No. 5, October 2015.
- [12] V. Tsagaris, V. Anastassopoulos, and G. Lampropoulos, "Fusion of hyperspectral data using segmented PCT for enhanced color representation", *IEEE Trans. Geosci. Remote Sens.*, Vol. 43, No. 10, 2005, pp. 2365–2375.
- [13] A.Harika, "Image Fusion Based On Dtcwt&PcaIn Presence Of Noise", *International Journal of Advanced Research in Computer and Communication Engineering* Vol. 3, Issue 11, November 2014, ISSN (Online): 2278-1021.
- [14] Manu V T and Philomina Simon "A Novel Statistical Fusion Rule For Image Fusion And Its Comparison In Non Sub-sampled Contourlet Transform Domain And Wavelet Domain", *International Journal of Multimedia & Its Applications (IJMA)* Vol.4, No.2, April 2012.
- [15] <http://in.mathworks.com/matlabcentral/answers/40897-links-to-matlab-documentation-in-published-html-pages>.