

# Pilot Tone based Gaussian Particle Filtering Approach for Carrier Frequency Offset Estimation in OFDM Systems

Eram Ahmed

Department of Electronics & Communication  
Engineering,  
Sagar Institute of Research & Technology, Bhopal

Minal Saxena

Department of Electronics & Communication  
Engineering,  
Sagar Institute of Research & Technology, Bhopal

## ABSTRACT

Now these days OFDM is widely used for data communication. OFDM is used for transferring the high data rate. But there are some disadvantages of OFDM one of them is Carrier frequency offset. The cause behind the CFO is the synchronization between frequencies. It is a very sensitive so that hard to manage these frequencies. This paper presents a hybrid technique for carrier frequency offset (CFO) estimation in orthogonal frequency division multiplexing (OFDM) over frequency selective fading channel by using pilot tone and Gaussian particle filtering (PF) approach. An analytic expression in form of mean square error (MSE) of frequency offset synchronization is reported, and simulation results verify theoretical analysis and show approximate 97% improvement.

## Keywords

OFDM Frequency estimation, carrier frequency offset

## 1. INTRODUCTION

The rapid growth of high data rate transmission makes a need to improve the performance of a network. This can be made easy by using Orthogonal Frequency Division Multiplexing. OFDM is a approach in which the multicarrier transmission technique have been used for wireless communication. Here the high data rate has been use to transmit the data. This high data can be divided into various sequences of the data. These sequences can be concurrently transmitted by the sub carriers. The IEEE 802.11a includes the OFDM as a standard due to its robustness under multipath fading conditions

OFDM system is widely used modulation schemes in multi-carrier. In this modulation all subcarriers are orthogonal to each other, thereby increasing the bandwidth efficiency of the system. OFDM channel transmission frequency band becomes flat fading channel narrowband channel through each sub channel. OFDM modulation and de-modulation is employed proficiently by inverse discrete Fourier transform and discrete Fourier transform at the transmitter and receiver respectively [1]. Cyclic prefix (CP) is used for the extension of the OFDM symbol in the time domain, which increases the robustness of OFDM against inter symbol interference (ISI). OFDM has been used largely the implementation of wireless IEEE 802.11a / g standard wireless local metropolitan wire, Broadcast audio and video standard digital terrestrial broadcasting.

The orthogonal frequency division multiplexing (OFDM) is mainly used in modern and future communication systems, such as LTE, because of its various advantages; in particular code inserted prefix avoids the hassle of interference between traditional symbols of communication. In addition, inter-carrier interference is inevitable (ICI) caused by frequency offset carrier problem (CFO) because symbol synchronization timing may not be perfect at the receiver. Therefore, the acquisition of

synchronization and more accurate symbol offset estimation in OFDM systems are desired.

A number of conventional approaches[1], the Kalman filter (KF) particle filter (PF) [2,3], etc. have been proposed to fight against here. Proposed in [5] classical approaches - [4] (we refer to them as a method of Moose, the method of Morelli-MENGALI, and Schmidl-Cox method, respectively) are based on the maximum likelihood estimation (MLE) and the best linear unbiased estimate (BLUE) criteria. Since the CFO is not a linear estimation problem, and furthermore, the problem cannot be solved in closed form MLE, PF approaches are highly relevant for a better performance. However, occasionally PF reducing particles (IP) problem arising from resampling. Problem IP results in particles having a higher weight often statistically selected; consequently, the resulting particles contain many repeated after a few iterations [7] particles. Generally, PI is serious when the noise of the state of the process is very low or zero in the equation of dynamic state. For the estimation of CFO, the process noise is modeled zero state. PI phenomenon degrades performance as poor identical particles cannot converge to the true value, and the phenomenon can be withdrawn only enough particles are used. In this paper, we propose approaches PF and study its performance for the problem of estimating CFO. Auxiliary PF (APF) and the probability PF (LPPF) is proposed in [5] and [8], respectively, but the job status of the system model is different from our model. If APF is adopted for our model, the algorithm becomes the same as sequential importance resampling (SIR) PF (SIR PF is also studied in this work). LPPF and cannot be used in our model because all weights become zero. PI PF knows Gauss (due process of re-sampling is not necessary in GPF) shows the best performance among approaches PF, and also surpasses all well known conventional approaches, namely, moose, Schmidl-Cox (SC) and Morelli (MM) in addition to previously proposed methods -Mengali approaches (eg, KF series PF). Indeed, one advantageous feature GPF FP inherent nonlinear estimation problem; In addition, at the same time avoids the problem is disadvantageous in that PI function PF of a static parameter estimation.

## 2. RELATED WORK

This paper [7] presents frequency offset estimation algorithm in wireless OFDM cellular system such as 3G-LTE. We first analyze the method of frequency offset estimation in general OFDM system. The analysis will show that the value of frequency offset estimation in cell boundary is inaccurate. Because doppler frequencies of signals transmitted from different base stations are different, the error of frequency offset estimation value is generated. We show how proposed algorithm can reduce the error of frequency offset estimation. Results of simulation show that the utilization of proposed algorithm can reduce the error of frequency offset estimation considerably. Proposed frequency offset estimation algorithm can increase

overall system capacity because of performance improvement in cell boundary. Especially, 16-QAM or 64-QAM modulations for high data rate transmission is extremely sensitive to frequency offset, therefore proposed algorithm increases channel capacity for user in cell boundary.

A new joint frame[8] synchronization and carrier frequency offset estimation scheme in orthogonal frequency division multiplexing (OFDM) systems is proposed in this paper, where both frame synchronization and carrier frequency offset estimation can be performed by using only ONE training symbol. Frame synchronization and carrier frequency offset acquisition are performed simultaneously in the proposed scheme. Reliable frame synchronization is obtained in the proposed scheme even in low SNR. The maximum carrier frequency offset acquisition range of the proposed scheme can be up to one half of the total signal bandwidth. The same training symbol can also be utilized to carrier frequency offset Fine Adjustment, which estimates the remaining carrier frequency offset after acquisition with higher accuracy. The performance comparison of the proposed Fine Adjustment algorithm and Schmid's algorithm by using computer simulation illustrates and verify the superior performance of the proposed algorithm with regard to estimation accuracy.

This paper [9] presents a basic useful technique for carrier frequency offset (CFO) estimation in orthogonal frequency division multiplexing (OFDM) over frequency selective fading channel. The performance of OFDM system is very sensitive to CFO, which introduces inter-carrier interference (ICI). In cyclic prefix (CP) based estimation, the CFO can be found from the phase angle of the product of CP and corresponding rear part of the OFDM symbol. In CFO estimation using training symbol, the CFO estimation range can be increased by reducing the distance between two blocks of samples for correlation. This was made possible by using training symbol that are repetitive with shorter period. An analytic expression in form of mean square error (MSE) of frequency offset synchronization is reported, and simulation results verify theoretical analysis.

This work [10] considers the effect of timing errors on the carrier frequency offset (CFO) estimation for orthogonal frequency division multiplexing (OFDM) systems. In general, most of the research conducted on OFDM systems assume that a wide range of timing errors can be tolerated due to the use of cyclic prefix (CP). Although such assumption might be valid for bit error rate (BER) analysis, it might not be the case for other processes such as CFO estimation. In this work, Monte Carlo simulations have been used to evaluate the effect of timing errors on the performance of several state-of-the-art CFO estimators for OFDM systems. The considered estimators include time domain, frequency domain, data-aided (DA) and blind estimators. Simulation results confirmed that particular CFO estimators, which are known to be highly accurate in perfect timing conditions, are very sensitive to timing offsets even if the offsets are within the inter-symbol-interference (ISI) free region of the CP. Other estimators offered high robustness for timing offsets in the entire range of the CP region. However, most of the considered estimators suffered from severe performance degradation for timing errors out of the CP region.

For Orthogonal frequency division multiplexing (OFDM) systems [11], the bandwidth is divided into many subcarriers, requiring a highly accurate frequency offset estimator. In this paper, a novel frequency offset estimator utilizing the periodicity embedded in a training symbol is proposed. We generalize the well known correlation-based methods such that the estimation range of all the correlations embedded in a training symbol can be extended to the maximum. These correlations can thus be

utilized freely without degrading the estimation range. Since only one training symbol is needed, the transmission efficiency is increased. The proposed method needs only the periodicity of the training symbol which leaves the design of pilot symbol for other considerations such as timing synchronization and channel estimation. To implement this estimator, a low-complexity algorithm is introduced. Performance analysis and simulation results are both given to compare with previously proposed best linear unbiased estimator (BLUE) and the superiority of our proposal is witnessed.

In [12] author proposes Gaussian particle filtering (PF) approach for estimating carrier frequency offset (CFO) in OFDM systems. PF is more powerful especially for nonlinear problems where classical approaches (e.g., maximum likelihood estimators) may not show optimal performance. Standard PF undergoes the particle impoverishment (PI) problem resulting from re-sampling process for this static parameter (i.e., CFO) estimation. Gaussian PF (GPF) avoids the PI problem because re-sampling process is not needed in the algorithm. They show that GPF outperforms current approaches in this nonlinear estimation problem.

### 3. ORTHOGONAL FREQUENCY DIVISION MULTIPLEXING

As earlier section it seems to be that the Orthogonal Frequency Division Multiplexing is approach in order to provide the fast service during the communication network. It can achieve by the concept of subcarrier in which the parallel transmission can possible. Here is a block diagram of transmitter and receiver for the OFDM.

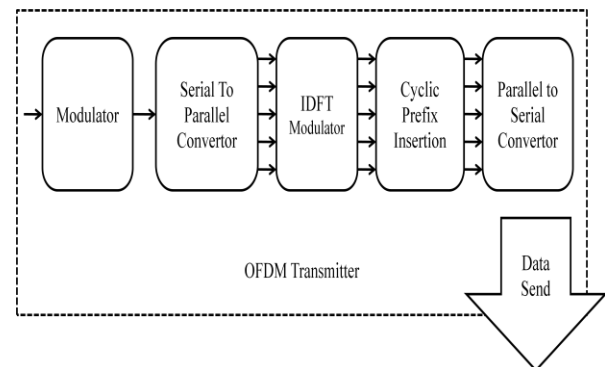

**Figure 1 Transmitter for OFDM**

The figure 1 shows the transmitter of the OFDM System. There are some small component has used like modulator serial to parallel convertor etc.

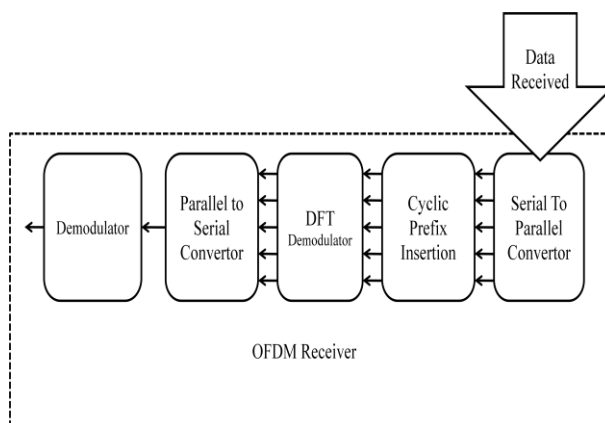

**Figure 2 Receiver of OFDM**

This block diagram is implemented for the receiver of the end user. It is a reverse process of the transmitting end.

#### 4. PROPOSED METHODOLOGY

In CFO estimation by using frequency domain involve the assessment of each phase of the carrier for each symbol in the following, the symbol in the phase shift due to the carrier frequency offset. Two different evaluation methods to estimate CFO estimation method based on the pilot is used, which is the acquisition and tracking mode. In the acquisition CFO estimation method is powerful and made the tracking mode is estimated that the fine CFO. Initially, it is assumed that the estimated purchase has already been done so well and CFO estimation is made in this paper. All simulation results show the mean square error (MSE) with respect to different signal-to-noise ratio (SNR) in dB and learning with respect to a ratio of the length of the OFDM symbol sequence of the repeat sequence respect to various CFO values.

Gaussian Particle Filtering Approach for Carrier Frequency Offset Estimation in OFDM Systems having particle impoverishment problem ie particles having higher weight statistically selected many times which is inappropriate for performance enhancement.

In this paper proposed solution incorporate FFT Based Superimposed Pilot Aided approach with existing Gaussian Particle Filtering Approach for Carrier Frequency Offset Estimation in OFDM Systems in order to detain particle impoverishment problem.

For CFO estimation in OFDM in this paper a pilot based Gaussian particle filtering approach has been proposed which employed pilot tone insertion mechanism for frequency domain and transmit every OFDM symbol for CFO tracking.

Towards the CFO estimation in OFDM initially Pilot tones are inserted into the frequency domain and transmit each OFDM symbol for CFO tracking as show in figure 3. For that first signals are altered into

$$P_l[i]_{i=0}^{x-1} \& P_{l+d}[i]_{i=0}^{x-1} \dots\dots\dots 1 \quad [9]$$

Through FFT (Where PL[i] denotes the Lth transmit symbol at ith sub-carrier) on or after where pilot tones are extracted. Once the estimation of CFO from pilot tones in the frequency domain  $\alpha$  ( ie frequency offset estimation) is done as show in equation 2, then the signal is remunerated with the estimation of CFO in the time domain also. In order to precede this process CFO estimation are implemented into two different modes namely acquisition and tracking modes. Acquisition mode is responsible for estimating large range of CFO, whereas tracking mode responsible only for fine CFO estimation.

$$\hat{\alpha} = \left( \frac{1}{2\pi T_{SUB}} \right) \max(\alpha) \left\{ \sum_{j=0}^{l-1} p_{l+d}[a[j], \alpha] q_{l+d}^*[a[j], \alpha] q_l[a[j]] \right\} \dots\dots 2 \quad [11]$$

Where l, a[j] and ql[a[j]] represent number of pilot tone, location of Jth pilot tone and q is the pilot tone located at a[j] location in the frequency domain at lth symbol periods.

Then filter particles approach Gauss (PF) to estimate the carrier frequency offset (CFO) systems. PF in OFDM is stronger especially for nonlinear problems where traditional approaches like maximum likelihood estimators cannot show the best

performance. PF suffers the problem of reducing the standard particles (PI) due to re-sampling the static parameter (ie CFO) estimation. Gaussian PF (GPF) inhibits IP problem because the process of re-sampling is not required in the algorithm.

The GPF approximates filtration and predictive Gaussian densities on a frame PF. The GPF updated recursively as posterior mean and covariance of the parameter of interest (ie CFO). The basic idea is to represent a PF density (for example filtering or higher density) samples generated and their associated weights. Then approximate particle density filtration and weight is displayed. The approximation of the density of particles filtered and weight as

$$p(x_k|y_k) = \sum_{i=1}^M w_k^i \alpha(x_k - x_k^i) \dots\dots\dots 3 \quad [11]$$

Where i represent particle and k represent its time index whereas M denote total particle number. Then on the basis of that particles weight proposed approach estimate CFO for frequency offset as show in figure 1, 2 that represent estimated timing and frequency offset respectively.

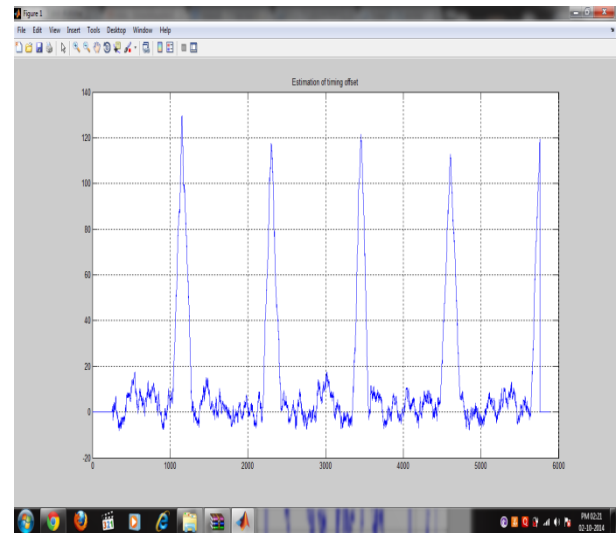

Figure 1:- Time offset estimation

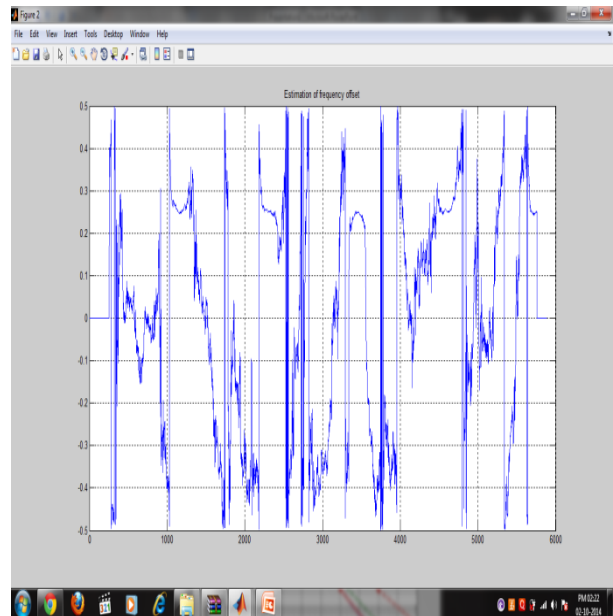

Figure 2:- Frequency offset estimation

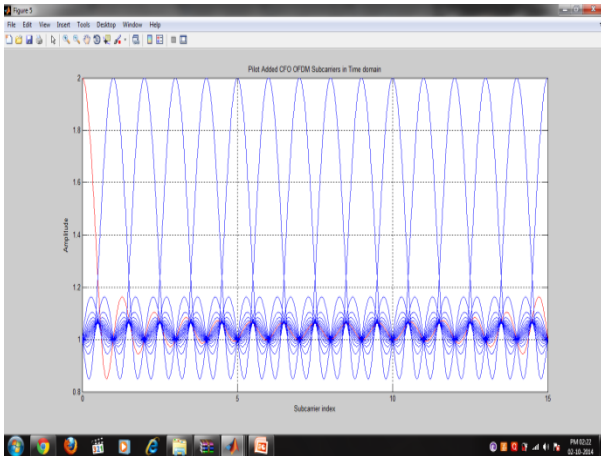

Figure 3:- Pilot added OFDM estimation

## 5. SIMULATION AND PERFORMANCE EVALUATION

To simulate the proposed work the implementation has done in MATLAB. The execution has been done on the i3 processor with 4 GB RAM and 500 GB HDD. We compare MSE performance of all the considered approach namely RPF, Morelli, moose CRB with proposed Pilot GPF and existing GPF as show in figure 4 and in table 1.

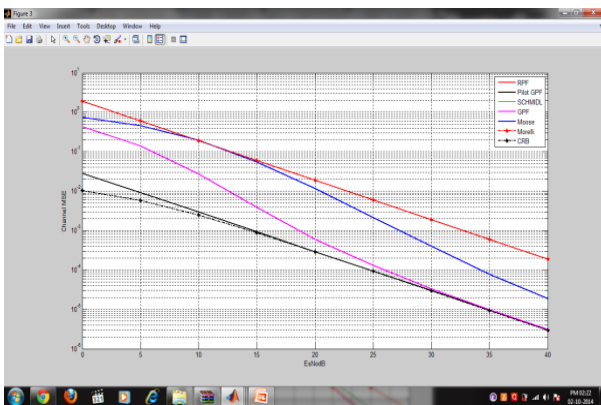

Figure 4: Comparison of MSE

Table 1:- MSE comparison between all existing and proposed Pilot GPF

TECHNIQUE	Es/NodB									AVERAGE
	0	5	10	15	20	25	30	35	40	
Morellie	1.8876	0.5966	0.1887	0.0605	0.0189	0.006	0.0019	0.0006	0.0002	0.306778
CRB	0.0285	0.0091	0.003	0.0009	0.0003	0.0001	0	0	0	0.004656
GPF	0.4298	0.1426	0.0277	0.0039	0.0006	0.0001	0	0	0	0.067189
Moose	0.7369	0.4616	0.1941	0.0546	0.0115	0.0022	0.0004	0.0001	0	0.162378
SCH	0.7	0.4	0.1	0.0	0.0	0.0	0.0	0.0	0	0.1623

MIDL	369	616	941	546	115	022	004	001		78
Pilot GPF	0.0102	0.0058	0.0025	0.0009	0.0003	0.0001	0	0	0	0.0022

Along with that BER sensitivity is also being compared as show in figure 5.

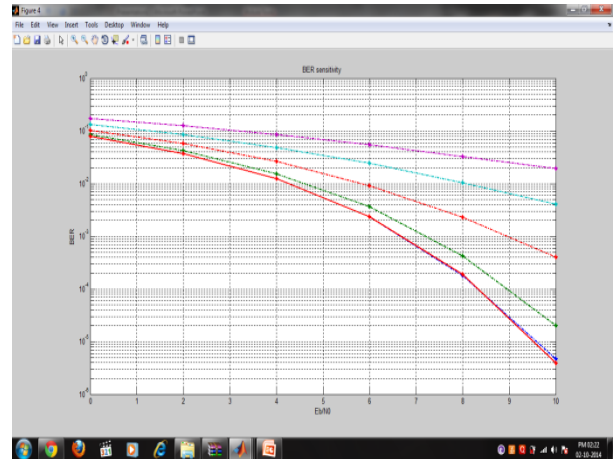

Figure 5: Comparison of BER Sensitivity

## 6. CONCLUSION

OFDM is an emerging field in the world of wireless communication. In this way there are lots of challenges are also in front of us. This paper is a brief description on the OFDM and their issues. These are lots of problem have to face in the frequency offset estimation. In this paper, a pilot based GPF approach for CFO estimation has been proposed. Pilot tone insertion mechanism for frequency domain and transmit every OFDM symbol for CFO tracking. Then filter particles approach Gauss (PF) to estimate the carrier frequency offset (CFO) systems. The proposed pilot-GPF shows the outperforming results for the highly non-linear problem over all range of levels for this static parameter estimation by taking advantage of its robustness against PI problem. Mean square error rate of proposed Pilot Gaussian filter added OFDM (MSE = 0.002) is much more less than existing GPF based approach (MSE= 0.067).Which is nearly 97.01 % improvement. Basically, the classical approaches (i.e., MM, SC, the Moose method, and iterative method) that are based on BLUE/MLE have limitation in the performance due to the highly nonlinear model of measurement equations in the CFO estimation.

## 7. REFERENCES

- [1] R. V. Nee and R. Prasad, "OFDM for Wireless Multimedia Communications", Artech House, pp.229-231, 2000.
- [2] A.P.Palamides and A.M.Maras, "A Bayesian state-space approach to combat inter-carrier interference in OFDM systems," IEEE Signal Process. Lett., vol. 14, no. 10, pp. 677-679, Oct. 2007.
- [3] J. Lim and D. Hong, "Inter-carrier interference estimation in OFDM systems with unknown noise distributions," IEEE Signal Process. Lett.vol. 16, no. 6, pp. 493-496, Jun. 2009.
- [4] P. H. Moose, "A technique for orthogonal frequency division multiplexing frequency offset correction", IEEE Transactions on Communications, Vol. 42, No. 10, October 1994.

- [5] J.A.C. Bingham, "Multicarrier modulation for data transmission: an idea whose time has come," *IEEE Commun. Mag.*, vol. 28, no. 5, pp. 5-14, May 1990.
- [6] Y. Yingwei and G. B. Giannakis, "Blind carrier frequency offset estimation in SISO, MIMO, and multiuser OFDM systems," *IEEE Trans. Commun.*, vol. 53, pp. 173-183, Jan. 2005.
- [7] Z. Xiang and A. Ghayeb, "A blind carrier frequency offset estimation scheme for OFDM systems with constant modulus signaling," *IEEE Trans. Commun.*, vol. 56, pp. 1032-1037, 2008.
- [8] Zhongshan Zhang, Keping Long, Ming Zhao, and Yuanan Liu, "Joint Frame Synchronization and Frequency Offset Estimation in OFDM Systems" *IEEE 2005*, pp. 389-394
- [9] Praween Kumar Nishad and P. Singh, "Carrier Frequency Offset Estimation in OFDM Systems", *IEEE 2013* pp 885-889.
- [10] S. Younis, Al-Dweik, C. C. Tsimenidis, B. S. Sharif and A. Hazmi "The effect of timing errors on frequency offset estimation in OFDM systems" in 11 Proceedings of the 2011 IEEE International Symposium on Signal Processing and Information technology, IEEE Computer Society Washington, DC, USA ©2011, pages 202-206
- [11] Chi Kuo, Jin-Fu Chang "Generalized Frequency Offset Estimation in OFDM Systems Using Periodic Training Symbol" in Conference: Communications, International Conference on, Volume: 1, IEEE-2005
- [12] Jaechan Lim and Daehyoung Hong, "Gaussian Particle Filtering Approach For Carrier Frequency Offset Estimation In OFDM Systems" In *IEEE Signal Processing Letters*, Vol. 20, No. 4, April 2013