

# Design and Development of Smart Home Environment Systems

Adarsh S P  
Dept. of I T  
SJCE  
Mysuru

Darshan R  
Shet  
Dept. of I T  
SJCE  
Mysuru

Priyanka  
Barki  
Dept. of I T  
SJCE  
Mysuru

Vivek S  
Dept. of I T  
SJCE  
Mysuru

Mallikarjuna  
swamy M.S  
Dept. of I T  
SJCE  
Mysuru

## ABSTRACT

Home automation refers to the use of computer and information technology to control home appliances. Systems can range from simple remote control of lighting to complex computer/micro-controller based networks with varying degrees of intelligence and automation. Home automation is adopted for reasons of ease, security and energy efficiency. The main aim of this work was to create a smart home environment system which includes features like automatic light systems, sprinkler system, intelligent gate system (I-gate) which opens and closes automatically and escalator system designed specifically for blind. Infrared (IR) sensors were used for I-gate and escalator system. Two IR sensors were used for I-gate and for IR sensors were used for escalator system. Passive Infrared (PIR) sensor and photodiode were used for automatic lighting systems. Sprinkler system makes use of soil moisture sensor, temperature sensor and rain sensor. Actuators used in this work were dc pump for sprinkler system, stepper motor for I-gate system and dc motor for escalator. Microcontrollers Atmega 32 and Atmega 8 were used to develop smart home environment system.

## General Terms

Automation, Instrumentation systems, Intelligent system

## Keywords

Home automation, microcontroller, escalator, blind, energy conservation

## 1. INTRODUCTION

Home Automation (HA) is quite a broad area and therefore has a variety of uses. Some areas are very important and can greatly improve the quality of life of an individual, while other aspects of HA are used for convenience rather than an essential item. The most essential aspect of HA is the security system, where cameras and other sensors can be used to sense and record the activity around a building/house.[1] Another essential issue in HA is applications for the senior citizen and for the physically challenged.[2] Automated systems can be linked to motors and switches to perform tasks controlled on a simple control panel. The most dominant uses of HA are with home lighting, multimedia and smart home appliance control. This tends to be the more exclusive market and often quite expensive.

## 2. EARLIER WORK

Home automation technology and smart home was a sciencefiction during the 1920s. Based on human's smart

technology and up gradation of process, the home automation system has

found its importance. During early part of 1990s, the consumer electronics devices were first digital formatted, which lead to digital information transmission. Since then there is continuous development taking place in the field, like home appliances hard wire connection to computer and later to wireless connection.[3]

O. Shoewu et al [4] developed a microprocessor based gate control system, where in the work four sensors were used which lead to difficulty in hardware implementation and installation. The automatic railway gate control system was developed by Acy M. Kottalil et al [5] using three IR sensors and two servo motors. Rohaida Husin et al [6] developed the automatic street lighting system for energy efficiency based on low cost microcontroller used LDR sensor which changes its resistance depending upon the intensity of light and gives different analog voltages. They quote that the major drawback in this system was poor sensitivity of LDR and less accuracy.

S. V. Devika et al [7] in their work used the sprinkler system for plant irrigation. Arduino based automatic plant watering system was developed where the humidity was the only parameter measured, whereas Gunturi [8] in their work monitored both humidity and temperature. The major drawback with the humidity sensor, is that, if there is no humidity in soil and suddenly it starts raining then the system implemented fails.

Based on the studies of earlier work the necessity of smart home automation system was understood and objective was set to design such a system. The objective of this work was to design and develop home automated system with features of automated lights, escalators specially designed for blind, automatic gate opening/closing and sprinkler system. I-gate system automatically opens and closes the gate and acts as an intelligent security system. The escalator is particularly designed for the blind which may make normal people uncomfortable to use, which is the only limitation of this project.

In this work, photodiode is used as sensor which has just two voltage levels providing better accuracy than LDR. Sprinkler system used accounts for rain, I-gate system is designed with just two IR sensors and one stepper motor hence simplifying hardware design and installation problem. Now a days lifts are available for blind which work on voice recognition, but till date, there is no escalators designed for blind. In this work an escalator is built which is useful for both normal and the blind.

### 3. METHODOLOGY

The developed smart home environment system consists of four main features of a smart home environment system namely, automatic light system, sprinkler system, I-gate for security and escalator for blind. The schematic representation for smart home environment system is shown in the Figure 1.

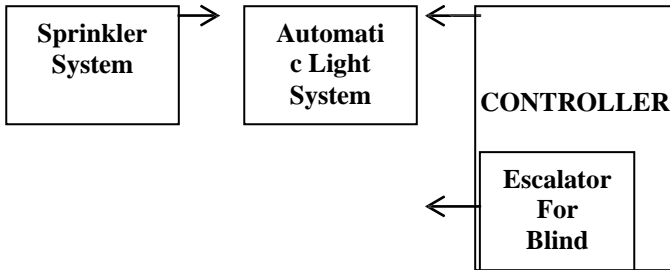

**Fig 1: Schematic representation for smart home environment system**

In automatic light system PIR sensor and photodiode were used to switch lights ON and OFF on presence of human and depending upon the intensity of light respectively. In sprinkler system three parameters namely, soil moisture, temperature and rain were measured and microcontroller switches the dc pump ON or OFF. Microcontroller Atmega 32 drives the stepper motor using ULN2003A depending upon the output of IR sensors for I-gate system. Microcontroller drives dc motor by a driver IC L293D to run the escalator according to the output from four IR sensors.

#### 3.1 Automatic Light Systems

##### Automatic switch on/off of lights on detecting a human

When a person enters a corridor or lift, light will switch ON automatically and will remain ON until there is presence of human in the vicinity of the PIR sensor. The block diagram of PIR sensor and its interface is shown in Figure 2.

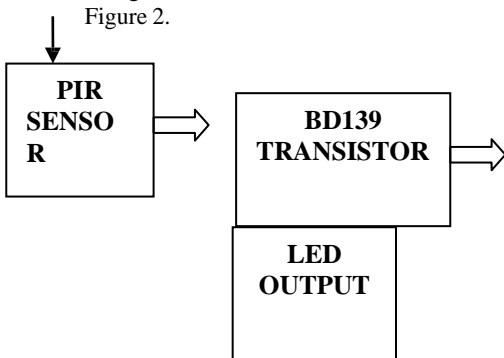

**Fig 2: Block diagram of PIR sensor**

The PIR sensor senses the light and outputs a current of 20mA. Here a white LED requiring 40mA and 3.3V is used hence the power is calculated as:

$$\text{Power rating of white LED} = 40\text{mA} \times 3.3\text{V} = 132\text{mW} \dots \dots (1)$$

Four LEDs are used in work hence the total power required is approximately 1W. To have a provision for connecting more number of LEDs, transistor having power rating of 2W was used, so the transistor BD139 with power rating

of 2W and collector current of 2A is used here.

##### Automatic switch on/off of lights based on light intensity

Depending upon the weather conditions, the lights around the building like an apartment, office, college campus will be switched ON and OFF automatically. In the presence of light, the photodiode outputs high and as lights fades it will output zero. During dawn the fencing light will be OFF, and as the day approaches dusk, lights will be switched ON

automatically. The circuit for automatic lighting system is shown in Figure 3.

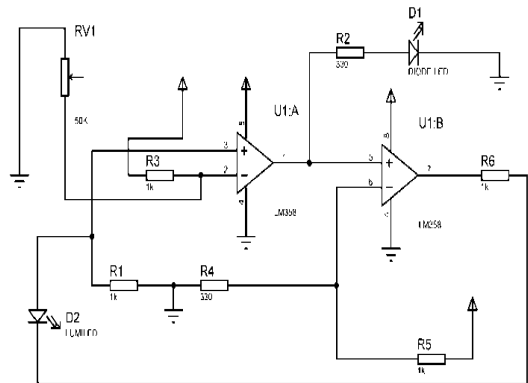

**Fig 3: Circuit design of automatic lights on/off using photo diode**

Photodiode output is given to pin 3 of the comparator which compares this input with reference voltage. When input at pin3 is higher than reference voltage, the comparator outputs 3.34V which in turn switches on a LED. The output of the comparator is further given to voltage follower whose output will be high when light the voltage is given to voltage follower whose output will be high when light is falling on the photodiode.

#### 3.2 Sprinkler System

For this system output is regulated by three parameters and they are, namely

- Soil moisture
- Rain
- Temperature

Depending upon the above parameters the output of the sprinkling system, that is, dc pump is either switched on or off as shown in the Table 1.

**Table I Operating conditions in sprinkling system**

Conditions	Rain sensor	Soil moisture sensor	Temp sensor	Output - dc pump
1	High	High	High	Off
2	High	High	Low	Off
3	Low	High	Low	Off
4	High	Low	High	Off
5	Low	Low	High	On
6	Low	Low	Low	On

If there is rain then it is termed as high else low. If there is moisture content in soil then it is termed as high else low. If temperature is above 33°C then it is termed as high else low.

The signal conditioning circuit for soil moisture sensor is shown in the Figure 4. The soil moisture sensor acts as a variable resistor. That is, when the moisture in the soil is more, because of the presence of more water the conductivity between the electrodes of the sensor increases. Hence, resistance offered by the sensor decreases and vice versa. The capacitor was used for removing noise.

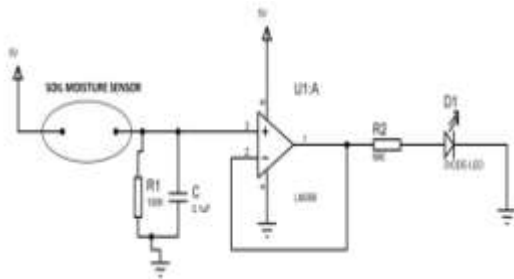

**Fig 4 Circuit diagram of soil moisture sensor**

The soil moisture sensor along with 100kΩ acts as a voltage divider circuit. The output of voltage divider circuit is given to pin 2 of LM358 which is actually an input to voltage follower. When there is no moisture content in soil the output of LM358 is low and when there is moisture content in soil the output of LM358 is high. When there is no moisture soil offers very high resistance therefore very low voltage is at the input of voltage follower so output is also low. When there is moisture content in soil, soil offers low resistance therefore output of voltage divider is high so input to voltage follower is high hence output of voltage follower is high.

The signal conditioning circuit for rain sensor is shown in the Figure 5.

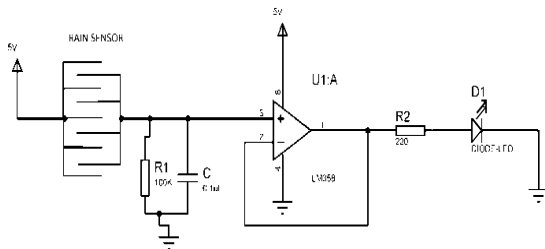

**Fig 5: Circuit diagram of rain sensor**

The capacitor is used for removing noise. The rain sensor along with 100kΩ acts as a voltage divider circuit. The output of voltage divider circuit is given to pin 2 of LM358 which is actually an input to voltage follower. When there is no rain the output of LM358 is low and when there is rain, the output of LM358 is high. When there is no rain there is no conductivity between two probes of wire therefore very low voltage is at the input of voltage follower so output is also low. When there is rain there is complete conductance between the two probes of sensor therefore output of voltage divider is high so input to voltage follower is high hence output of voltage follower is high.

The DS1820 Digital Thermometer provides 9-bit temperature readings which indicate the temperature of the device. Range of temperature that this temperature sensor measures is -55°C

to 125°C. Advantages of this temperature sensor above other temperature sensors are that it needs only one pin for communication with microcontroller and can connect multiple units on same one wire. DS1820 is a one wire protocol temperature sensor which internally consists of a RTD, A/D convertor working with successive approximation, a controller and many registers such as TH, TL and so on. The controller within the sensor takes 4ms for one conversion.

The signal conditioning of DC pump is shown in the Figure 6.

The dc pump employed is a 5V water pump which requires 1A for dry run but requires just 50mA for full load. Base emitter voltage required for TIP122 is 5V.

$$V_{cc}=5V \dots\dots\dots(2)$$

$$V_{be}=(5V \times 100k)/(100k+10k) \dots\dots\dots(3)$$

$$V_{be}=5V \dots\dots\dots(4)$$

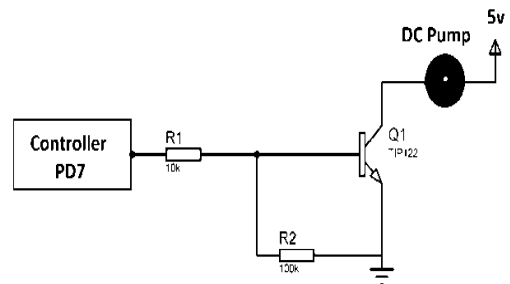

**Fig 6: Circuit diagram of DC pump**

Since reverse voltage from dc pump varies from 30V to 40V (typically 33V) TIP122 is used as it can withstand up to 100V.

### 3.3 I-gate system

The basic idea of I-gate system is that whenever the vehicle comes near the entry gate of an apartment or offices, this vehicle is sensed by IR sensor as the IR rays reach the receiver now due to reflection from the vehicle. Due to this reflection there is a change in input to microcontroller and then the microcontroller commands the actuator to open the gate. Hence it can be concluded that whenever the vehicle approaches the entry gate, the gate will be opened automatically and thus the name I-Gate. The Figure 7 shows the photograph of developed I-gate system which uses two IR sensors which are installed at two places. One sensor is before the gate and the other after the gate. The opening and closing of the gate is driven by the stepper motor. LED glowing red indicates gate is closed and when gate opens it glows green.



**Fig 7: I-Gate system**

The IR sensors were interfaced to microcontroller Atmega32. When one of the IR sensor detects the vehicle and other

doesn't detect any vehicle then uln2003A drives the stepper motor to rotate in +90degree. When the other sensor which was low while opening the gate becomes high the gate is closed which is done by running the stepper motor to rotate - 90 degree.

The receiver part consists of a photodiode is shown in Figure 8 which receives radiation when IR radiations are being obstructed by vehicle.

When photodiode receives radiations 5V is obtained at non inverting terminal of the op-amp. Here the op-amp acts as a comparator which compares the radiations received by the photodiode with reference voltage set by the voltage divider circuit using potentiometer which is used to set the sensitivity of the sensor. When photodiode receives the radiations the input at non inverting terminal is greater than the reference voltage set by the voltage divider circuit so output of op amp is +Vcc and LED D1 glows. This voltage is again compared with another reference voltage set using fixed resistors and given to controller. If more than one vehicle is entering the building then both the sensors remain high at the same time. In this case gate allows only one vehicle at a time for security reasons as the vehicles entering the building need to be checked.

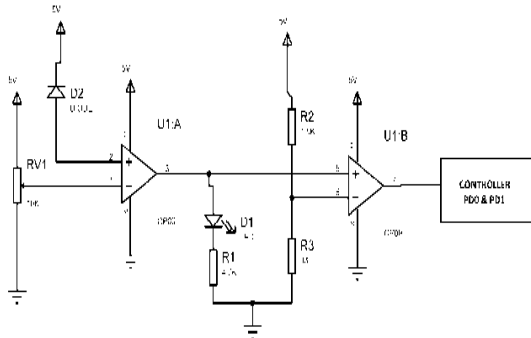

Fig 8: Receiver part of IR sensor

### 3.4 Escalator for Blind

By this system blind will be able to access escalators conveniently. In this work IR sensors were used as sensors to detect the presence of blind when persons steps on the first step of the escalator. When a blind steps on the first step IR radiations reach the IR receiver. This change gives rise to corresponding change in output voltage. The microcontroller gives commands to start the escalator. The command from the microcontroller is given to the IC L293D which drives the DC motor. There will be one more IR sensor at the top to detect when the person has reached the floor. On receiving signal from this sensor the controller stops the motor. The Figure 9 shows the photograph of developed escalator for blind consisting of four IR sensors. The two IR sensors were installed at the bottom in which one of the IR sensors is placed at the first step of the escalator and two IR sensors are installed at the top out of which one IR sensor is placed at the top most step of the escalator.



Fig 9: Developed escalator for blind

When a blind person comes in the vicinity of first IR sensor IR1, it senses the person with the increment in count and if the motor is in running condition (en=high) it sets the motor to be in stationary state. Once after the person crosses the second IR sensor IR2, it senses and motor starts to run. The motor runs until the person reaches the third IR sensor IR3. Once after the IR3 sensor senses the presence of the person and if en=high, the motor stops running with a buzzing sound which is an indication to the blind that he can get down from the escalator safely. When the person comes in the vicinity of IR4 the motor again starts to run and the count is decremented. If the count=0 and if the motor is still in running state, then it is switched off.

## 4. RESULTS

The main aim of this work was to create a convenient and easy going environment for the people, which was achieved successfully and the results of the system are tabulated here. When there was no light falling on photodiode there exists a leakage voltage which ranges from 0.53V to 1.10V. When this output is passed to voltage follower, since this voltage is lesser than 1.25V existing at pin 6 output at pin7 was zero (0.91V). The observed values are shown in the Table 2.

Table 2 Experimental results of photodiode

IC Pin s	Light (Not Sensed)			Light (Sensed)		
	1	0.53V	0.7V	0.9V	3.34V	3.33V
2	0V			0.2V	0.18V	0.2V
3	0V			0.7V	0.7V	0.7V
4	0V(GND)			0V(GND)		
5	0.46V	0.88V	1.04V	3.34V		
6	1.25V			1.25V		
7	0.91V	0.93V	0.96V	3.61V		
8	VCC(5V)			VCC(5V)		

The experiment was conducted for two conditions, one with moisture and other without moisture. Without moisture, the soil acts as a high resistance medium between the sensor probes and in the presence of moisture there exists a slight conductivity path between the sensor probes and hence the moisture content in the soil can be predicted as high. The experimental results obtained are shown in the Table 3.

**Table 3 Experimental results of soil moisture sensor**

IC Pins	Without Moisture	With Moisture
1	0.3V	3.37V
2	0.3V	3.37V
3	0.1V	3.27V
4	GND	GND

The experiment was conducted for two conditions, one with rain and other without rain. When there is no rain there is no conductivity path between the probes unlikely when it rains there exists a conductivity path between the probes as water acts as a conductive path between the probes. The experimental results obtained are shown in the Table 4.

**Table 4 Experimental results of rain sensor**

IC Pins	Without Rain	With Rain
1	0.02V	3.37V
2	0.02V	3.37V
3	0V	3.37V
4	GND	GND

The DS1820 measures temperature by counting the number of clock cycles that an oscillator with a low temperature coefficient goes through during a gate period determined by a high temperature coefficient oscillator. The counter is preset with a base count that corresponds to  $-55^{\circ}\text{C}$ . If the counter reaches zero before the gate period is over, the temperature register, which is also preset to the  $-55^{\circ}\text{C}$  value, is incremented, indicating that the temperature is higher than  $-55^{\circ}\text{C}$ . Internally, this calculation is done inside the DS1820 to provide  $0.5^{\circ}\text{C}$  resolution. The corresponding digital value for a given temperature is given in Table 5.

**Table 5 Experimental results of temperature sensor**

Temp.	Digital Output (Binary)	Digital Output (Hex)
$+125^{\circ}\text{C}$	0000000011111010	00FAh
$+25^{\circ}\text{C}$	0000000000110010	0032h
$+1/2^{\circ}\text{C}$	0000000000000001	0001h
$+0^{\circ}\text{C}$	0000000000000000	0000h
$-1/2^{\circ}\text{C}$	1111111111111111	FFFFh
$-25^{\circ}\text{C}$	1111111110011110	FFCEh
$-55^{\circ}\text{C}$	1111111110010010	FF92h

## 5. CONCLUSION

The system was designed and developed prototype of the system is shown in Figure 10. These features which have been designed are not just restricted to home or apartments but can also be implemented at offices and industries, shopping malls, airports, railway stations and so on. Sprinkler system can be further upgraded using RFID and

GSM based modules. I-gate system is designed only for unidirectional traffic and this can be further improved for bidirectional traffic. The security can be made effective by giving authorized entry using number plate recognition system, face recognition, Bluetooth decoding system etc. Escalator designed here is only for unidirectional purpose but it can also be implemented for bidirectional purpose. Currently in this work the commands for blind were given out by buzzer system, instead the commands can be given out by any voice related outputs which could be convenient for understanding purpose.



**Fig 10: Complete model of smart home environment system**

## 6. REFERENCES

- [1] Harper, Richard, ed.1, Inside the smart home, Springer, August 2003
- [2] Mann, William C., ed.1, Smart technology for aging, disability and independence: the state of science, John Wiley and Sons, July 2005
- [3] Joakim Börjesson, Victor Ström, Yiqi Mao, Kadri-Ann Valgeväli, Amir Sabbagh Pour, HomeAutomation, Project report, Chalmers University of Technology Göteborg, 2008
- [4] O Shoewu and O.T.Baruwa, Design of a microprocessor based automatic gate, The Pacific Journal of Science and Technology, Volume 7. Number 1. May 2006
- [5] Acy M. Kottalil, Abhijith S, Ajmal M M, Abhilash L J., Ajith Babu, Automatic railway gate control system, International Journal of Advanced Research in Electrical, Electronics and Instrumentation Engineering, Vol. 3, Issue 2, February 2014.
- [6] Rohaida Husin, Syed Abdul Mutalib Al Junid, Zulkifli Abd Majid, Zulkifli Othman, Khairul Khaizi Md Shariff, Hadzli Hashimand Mohd Faisal Saari, Automatic Street Lighting System for Energy Efficiency based on Low Cost Microcontroller, IJSS ISSN: 1473-804x 48 online, 13.01.05
- [7] S. V. Devika, Sk. Khamuruddeen, Sk. Khamurunnisa, Jayanth Thota, Khalesha Shaik, Arduino Based Automatic Plant Watering System, International Journal of Advanced Research in Computer Science and Software Engineering, Volume 4, Issue 10, October 2014
- [8] Venkata Naga, Rohit Gunturi, Micro Controller Based Automatic Plant Irrigation System, International Journal of Advancements in Research & Technology, Volume 2, Issue 4, April-2014