

Li- Fi based Voice Controlled Robot

Meenakshi Patil
Assistant Professor at
ICEM,
Paranwadi, Pune

Neha Joshi
B.E. pursuing at ICEM,
Paranwadi, Pune

Asmita Tilekar
B.E. pursuing at ICEM,
Paranwadi, Pune

Poonam Shinde
B.E. pursuing at ICEM,
Paranwadi, Pune

ABSTRACT

Li-Fi is a light fidelity. This is a technique use for transmission of data at very high speed through light, which transfers data by varying its intensity. This variation in light provides us binary 1 and binary 0 of data which transmit information wirelessly through Visible Light Communication (VLC). Using this technology we have proposed to implement a voice controlled robot. The commands for movement of robot are given by human which gets processed through MFCC voice recognition algorithm, this data is then transmitted through Li-Fi to the robot. Li-Fi is ideal or high density wireless data coverage inside confined area. Li-Fi technology is based on LEDs for the transfer of data. The transfer of the data can be with the help of all kinds of light, no matter the part of the spectrum that they belong. With this technology the speed of the internet is incredibly high and we can download movies, games, music etc in just a few minutes. This can be treated as a next version of Wi-Fi.

General Terms

Li-Fi, speech recognition algorithm

Keywords

Li-Fi, High-brightness LED, Photodiode, VLC, Wireless Communication, speech recognition algorithm.

1. INTRODUCTION

The project is “Li-Fi is based Voice Controlled Robot”. Li-Fi stands for Light-Fidelity. Li-Fi is transmission of data through light by varying its intensity. Li-Fi technology was first discovered by Dr. Harald Haas from the University Of Edinburgh. In this technology, LED and optocoupler is used. LED is used for transmission and optocoupler for reception. When LED is turned ON, binary value ‘1’ is transmitted, and when LED is OFF ‘0’ is transmitted. LED’s can be switched on and off very quickly, which proves transmission of data is successful by varying intensity of light source. It is possible to encode data in the light by varying the rate at which the LEDs flicker on and off to give different strings of 1s and 0s. The LED intensity is modulated so rapidly that human eye cannot recognize, so the output appears constant.

In this project, we are controlling the movements of robot through the voice of operator. The voice is made transferable through the speech algorithm in Matlab software. When we give commands to the robot, the voice is compared with the database with the help of MFCC algorithm. It will compare the two speech signals and if the voice is matched then it will give signal to the ARM7. Then these commands are transmitted through Li-Fi transmitter.

There is path of LED’s between transmitter and receiver. The Li-Fi receiver receives the signal and gives to the DC motor driver IC. The driver IC drives the DC motor and the movements of robot are achieved.

2. LITERATURE SURVEY

1. Jyoti Rani, Prerna Chauhan and Ritika Tripathi [1] provides transmission of data through illumination by sending data through an LED light bulb that varies in intensity faster than the human eye can follow. This paper focuses on developing a Li-Fi based system and analyzes its performance with respect to existing technology. Their envisions a future where data for laptops, smart phones, and tablets is transmitted through the light in a room. And security would be snap if we can’t see the light, we can’t access the data.

Researchers at the Heinrich Hertz Institute in Berlin, Germany, have reached data rates of over 500 megabytes per second using a standard white-light LED. The technology was demonstrated at the 2012 Consumer Electronics Show in Las Vegas using a pair of Casio smart phones to exchange data using light of varying intensity given off from their screens, detectable at a distance of up to ten meters.

If his technology can be put into practical use, every bulb can be used something like a Wi-Fi hotspot to transmit wireless data and we will proceed toward the cleaner, greener, safer and brighter future. The concept of Li-Fi is currently attracting a great deal of interest, not least because it may offer a genuine and very efficient alternative to radio-based wireless. As a growing number of people and their many devices access wireless internet, the airwaves are becoming increasingly clogged, making it more and more difficult to get a reliable, high-speed signal. This may solve issues such as the shortage of radio-frequency bandwidth and also allow internet where traditional radio based wireless isn’t allowed such as aircraft or hospitals.

2. Akshata M Sonnad, Anjana Gopan, Sailakshmi N R, Divya S And Ambika R [2] explained the era of wireless technology, the number of devices accessing the internet is growing by the minute. This has unfortunately led to an increase in network complexity, shortage of wireless radio bandwidth and an increased risk of interference of radio frequencies. Therefore, there is a pressing need to find new means of wireless communication which is fast, reliable and error free. One such technology that promises to alleviate the problems as stated above is Light Fidelity or simply, ‘Li-Fi’. Conventional wireless communication schemes like Wi-Fi predominantly use radio/micro wave frequencies for data transmission, primarily because of the availability of high sensitivity receivers and ability to provide broad coverage at low frequencies and line of sight communication at high frequencies. But, RF can support only a limited bandwidth due to confined spectrum availability. Therefore the expanding demand for wireless data has led to clogging of the radio spectrum. Li-Fi has great potential in the field of wireless data transmission. It is a promising alternative to conventional methods of wireless communications that use radio waves as data carrier. Many enhancements can be made to the existing technology.

3. Rahul R. Sharma [3] focuses on developing a Li-Fi based system and analyzes its performance with respect to existing technology. Wi-Fi is great for general wireless coverage within buildings, whereas Li-Fi is ideal for high density wireless data coverage in confined area and for relieving radio interference issues. Li-Fi provides better bandwidth, efficiency, availability and security than Wi-Fi and has already achieved blisteringly high speed in the lab. By leveraging the low-cost nature of LEDs and lighting units there are many opportunities to exploit this medium, from public internet access through street lamps to auto-piloted cars that communicate through their headlights. Haas envisions a future where data for laptops, smart phones, and tablets will be transmitted through the light in a room. The concept of Li-Fi is attracting a lot of eye-balls because it offers a genuine and very efficient alternative to radio based wireless.

It has a bright chance to replace the traditional Wi-Fi because as an ever increasing population is using wireless internet, the airwaves are becoming increasingly clogged, making it more and more difficult to get a reliable, high-speed signal. This concept promises to solve issues such as the shortage of radio-frequency bandwidth and boot out the disadvantages of Wi-Fi. Li-Fi is the upcoming and on growing technology acting as competent for various other developing and already invented technologies. Hence the future applications of the Li-Fi can be predicted and extended to different platforms and various walks of human life.

3. BLOCK DIAGRAM AND WORKING

In our system we are going to control the movements of robot through the voice of operator. And the voice is given through the mike. The Matlab software is used for the voice recognition. The actions performed on the robot are forward, backward, left and right. Once the voice is recognized it is ready to be transmitted. The electrical signal is transmitted through Li-Fi transmitter in the form of photons as it uses LED for transmission. It sends a data through a LED light bulb that varies in intensity faster than the human eye can follow. According to commands received by Li-Fi receiver the particular movement will take place.

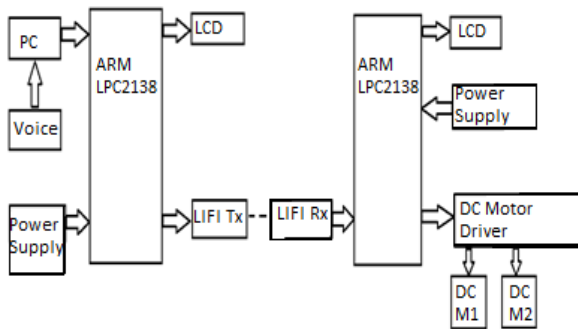

Figure1. Block Diagram of Li-Fi Based Voice Controlled Robot

3.1 Speech Recognition Using MFCC Algorithm

MFCC is Mel Frequency Cepstral Coefficient. Speaker recognition have two types: speaker recognition and speaker identification. This method automatically identifies who is speaking, on the basis of individual information integrated in speech waves. Speaker recognition is mostly applicable in use of speaker's voice to verify their identity and control the access to services such as banking by telephone, database access services, voice dialing telephone shopping, information services etc.

The MFCC technique used to extract features from the speech signal and compare the unknown speaker with the exist speaker in the database. Figure shows the complete pipeline of Mel Frequency Cepstral Coefficients. Fig.2. below shows the MFCC Algorithm.

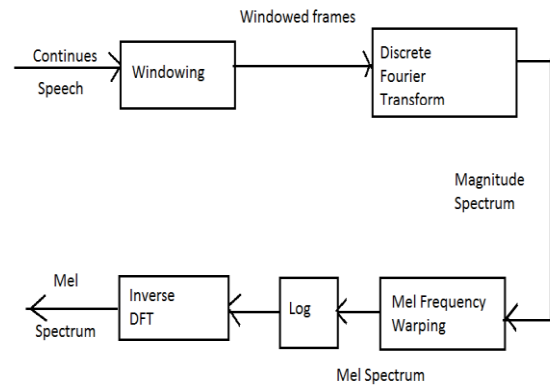

Figure2. MFCC Algorithm

Mel frequency Cepstral Coefficients are coefficients that represent audio based on perception. This coefficient has a great success in speaker recognition application. It is derived from the Fourier Transform of the audio clip. In this technique the frequency bands are positioned logarithmically, whereas in the Fourier Transform the frequency bands are not positioned logarithmically. As the frequency bands are positioned logarithmically in MFCC, it approximates the human system response more closely than any other system. These coefficients allow better processing of data. In the Mel Frequency Cepstral Coefficients the calculation of the Mel Cepstrum is same as the real Cepstrum except the Mel Cepstrum's frequency scale is warped to keep up a correspondence to the Mel scale. Here using the bank filter to warping the Mel frequency. Utilizing the bank filter is much more convenient to do Mel frequency warping, with filters centered according to Mel frequency. According to the Mel frequency the width of the triangular filters vary and so the log total energy in a critical band around the center frequency is included. After warping are a number of coefficients.

$$Y(k) = \sum_{j=1}^{N/2} s(j)Hk(j)$$

3.2 Li- Fi Transmitter and Receiver

After the voice signal is completely processed, it is transmitted through the LI-Fi transmitter. A new generation of high brightness light-emitting diodes forms the core part of light fidelity technology The LED is used to transmit data and at receiver photodiode is used to pick the signal. At transmitter if the LED is on, a digital 1 is transmitted. If the LED is off, a digital 0 is transmitted. The data being transmitted is in the form of photons. the series of light can be formed to increase the range of communication. This communication takes place wirelessly and uses visible light spectrum for the same.

These high brightness LEDs can be switched on and off very quickly and provides very high speed transmission of data through light. To build up a message, flash the LED numerous times or use an array of LEDs of perhaps a few different colors, to obtain data rates in the range of hundreds of megabits per second.

At receiver, the data transmitted is received by Li-Fi receiver. Then this signal is given to the controller ARM 7. The data received and the command for robot movement is displayed on LCD. Now the signal is fed to the DC motor driver IC L293D. This is responsible for the movement of DC motors of the robot

4. ADVANTAGES

4.1 Capacity

Light has 10000 times wider bandwidth than radio waves. Also, light sources are already installed. So, Li-Fi has got better capacity and also the equipments are already available.

4.2 Efficiency

Data transmission using Li-Fi is very cheap. LED lights consume less energy and are highly efficient.

4.3 Availability

Availability is not an issue as light sources is present everywhere. There are billions of light bulbs worldwide; they just need to be replaced with LEDs for proper transmission of data.

4.4 Security

Radio waves can penetrate through walls. They can be intercepted. If someone has knowledge and bad intentions, they may misuse it. But Light waves do not penetrate through walls. So, they cannot be intercepted and misused.

5. APPLICATIONS

5.1 Voice controlled robot

Li-Fi is a replacement of Wi-Fi for high speed data transmission rate. In industries robots are used to avoid any accidents that occurred because of workers mistakes. The Voice controlled robot is one of them. By using this robot we can control the movements of the robot. In this project movement of robot is controlled on the voice. The instructions of this operator are transmitted towards robot through Li-Fi technology wirelessly.

5.2 Airways

The airway communication takes place through radio waves but the range connectivity problem occurs. To overcome this drawback on radio ways, li-fi is introduced.

5.3 Education systems

LI-Fi can be used in educational institutions and at companies so that all the people can make use of Li-Fi with the same speed intended in a particular area.

5.4 Medical Applications

Operation theatres (OTs) do not allow Wi-Fi due to radiation Concerns. Usage of Wi-Fi at hospitals interferes with the mobile and pc which blocks the signals for monitoring equipments. So, it may be hazardous to the patient's health. To overcome this and to make OT tech savvy Li-Fi can be used in accessing internet and to control medical equipments. This can even be beneficial for robotic surgeries and other automated procedures.

6. CONCLUSION

Li-Fi technique provides very high speed as well as most efficient communication. The use of 1 light bulb in our project provides the communication range in one room. Hence use of multiple lights increases the range of communication.

7. RESULT

Pure voice after processed from MFCC algorithm gets transmitted towards Robot through 5Watt SYSKA LED path i.e. Li-Fi path and received by phototransistor. And accordingly robot moves.

8. REFERENCES

- [1] Jyoti Rani, Prerna Chauhan, Ritika Tripathi, "Li-Fi (Light Fidelity) The future technology in Wireless communication", International Journal of Applied Engineering Research, vol. 7 No.11, 2012, ISSN 0973-4562.
- [2] Akshata M Sonnad, Aanjana Gopan, Sailakshmi N. R, Divya S, Ambika R," Recent Advancements In Li-Fi Technology" , International Journal of Electrical, Electronics and Data Communication, ISSN: 2320-2084 Volume-1, Issue-10, Dec-2013
- [3] Rahul R. Sharma¹, Raunak, Akshay Sanganal "Li-Fi Technology Transmission of data through light" IJCTA, Jan-Feb 2014.
- [4] Visilink,-Visible Light Communication Technology for Near-Ubiquitous Networking| White Paper, January 2012.
- [5] www.seminarprojects.com/s/seminar-report-on-lifi
- [6] <http://en.wikipedia.org/wiki/Li-Fi>
- [7] en.wikipedia.org/wiki/Li-Fi
- [8] www.macmillandictionary.com/buzzword/entries/Li-Fi.htmldvice.com/archives/2012/08/lifi-ten-