

Comparison of Signal Scrambling PAPR Reduction Techniques with Signal Distortion Techniques in OFDM Signal

Karuna A. Mahajan
Elec & Comm. Engg. Dept.,
Institute of Technology,
Nirma University,
Ahmedabad, Gujrat.

Sunil V. Mukhare
Elec & TeleComm. Engg. Dept.,
B.N.College of Engineering
Amravati University,
Pusad, Maharashtra

Abstract— The concept of Orthogonal Frequency Division Multiplexing (OFDM) has been known since 1966, but it becomes popular in during 1990s. OFDM is an attractive modulation technique for transmitting large amounts of digital data over radio waves. A major drawback of orthogonal frequency division multiplexing is the high peak-to-average power ratio of the transmitted signal. Numbers of techniques have been proposed in the literature for reducing the PAPR in OFDM systems. These techniques are broadly categorized into signal distortion and signal scrambling techniques. In this paper the well known SLM and PTS Signal Scrambling PAPR reduction techniques are compared with that of most simple Clipping and Companding signal distortion techniques.

Keywords-Orthogonal frequency division multiplexing (OFDM), peak-to-average power ratio (PAPR), Partial transmit sequence (PTS), Selected Mapping(SLM) .

1.INTRODUCTION

The advent of 4G wireless systems has created many research opportunities. The expectations from 4G are high in terms of data rates, spectral efficiency, mobility and integration. Orthogonal Frequency Division Multiplexing (OFDM) is proving to be a possible multiple access technology to be used in 4G. But OFDM comes with its own challenges like high Peak to Average Power Ratio, linearity concerns and phase noise. The high PAPR introduces inter modulation distortion and undesired out-of-band radiation due to the nonlinearity of the high power amplifier (HPA). The distortion causes degradation of the bit error rate (BER) and high adjacent channel interference, respectively. Therefore, it is desirable to reduce the PAPR of an OFDM signal.

To date, various schemes attempting to reduce the PAPR have appeared in the literature. These are broadly classified into two types which are signal distortion and signal distortionless techniques. The more common schemes include in Signal distortionless techniques are block coding [2], tone reservation and injection [3], Active constellation Extension(ACE) technique [4], Selected mapping (SLM) scheme[5],[6], and Partial transmit sequence (PTS) schemes[7]–[11]. Among all these schemes, the SLM and PTS schemes have been considered the most attractive schemes due to its high PAPR reduction performance without incurring additional signal distortion. The signal distortion techniques includes Clipping[1], Peak Windowing and Companding[14]. This paper compares these two types of techniques and discusses their advantages and disadvantages. .

The rest of the paper is organized as follows. Section II describes about PAPR. In Section III, SLM and PTS schemes are described. Amplitude Clipping & filtering and Companding techniques are discussed in Section IV. In Section V, Comparison of these two schemes is done. Finally, we present conclusions in Section VI.

2.PEAK-TO-AVERAGE POWER RATIO

A multicarrier signal is the sum of many independent signals modulated onto sub channels of equal bandwidth. Let us denote the collection of all data symbols X_n , $n = 0, 1, \dots, N - 1$, as a vector $X = [X_0, X_1, \dots, X_{N-1}]^T$ that will be termed a data block. The complex baseband representation of a multicarrier signal consisting of N subcarriers is given by

$$x(t) = \frac{1}{\sqrt{N}} \sum_{n=0}^{N-1} X_n \cdot e^{j2\pi n \Delta f t}, \quad 0 \leq t < NT \quad (1)$$

Where $j = \sqrt{-1}$, f is the subcarrier spacing, and NT denotes the useful data block period. In OFDM the carriers are chosen to be orthogonal (i.e., $f = 1/NT$). The PAPR of the transmit signal is defined as

$$\text{PAPR} = \frac{\max_{0 \leq t < NT} [x(t)]^2}{\frac{1}{NT} \int_0^{NT} [x(t)]^2 dt} \quad (2)$$

In principle, PAPR reduction techniques are concerned with reducing $\max x(t)$. However, since most systems employ discrete-time signals, the amplitude of samples of $x(t)$ is dealt with in many of the PAPR reduction techniques. Since symbol spaced sampling of (1) sometimes misses some of the signal peaks and results in optimistic results for the PAPR, signal samples are obtained by oversampling (1) by a factor of L to approximate the true PAPR better. The L -times oversampled time-domain samples are obtained by an LN - point inverse discrete Fourier transform (IDFT) of the data block with zero-padding. It was shown in [12] that $L = 4$ is sufficient to capture the peaks.

3.SIGNAL DISTORTIONLESS TECHNIQUES

A. Selected Mapping Technique

In the SLM technique, the transmitter generates a set of sufficiently different candidate data blocks, all representing the same information as the original data block, and selects the most favorable for transmission [5, 6]. A block diagram of the SLM technique is shown in figure 1.

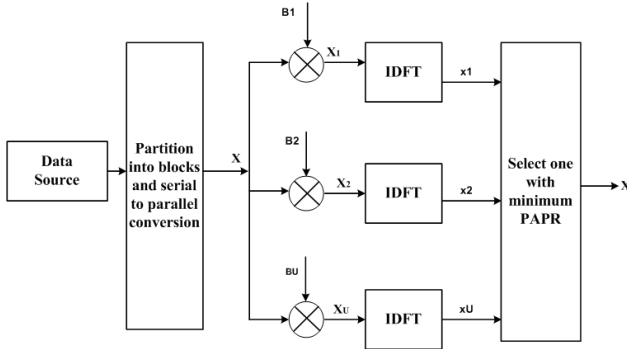

Figure 1. Block diagram of SLM scheme[5].

Each data block is multiplied by U different phase sequences, each of length N , $\mathbf{B}^{(u)} = [b_{u,0}, b_{u,1}, \dots, b_{u,N-1}]^T$, $u = 1, 2, \dots, U$, resulting in U modified data blocks. To include the unmodified data block in the set of modified data blocks, we set $\mathbf{B}^{(1)}$ as the all-one vector of length N . Let us denote the modified data block for the u^{th} phase sequence $\mathbf{X}^{(u)} = [X_0 b_{u,0}, X_1 b_{u,1}, \dots, X_{N-1} b_{u,N-1}]^T$, $u = 1, 2, \dots, U$. After applying SLM to \mathbf{X} , the multicarrier signal becomes

$$X^{(u)}(t) = \frac{1}{\sqrt{N}} \sum_{n=0}^{N-1} X_n b_{u,n} \cdot e^{j2\pi n \Delta f t}, \quad 0 \leq t < NT \quad (3)$$

Where $u = 1, 2, \dots, U$.

Among the modified data blocks $\mathbf{X}^{(u)}$, $u = 1, 2, \dots, U$, the one with the lowest PAPR is selected for transmission. Information about the selected phase sequence should be transmitted to the receiver as side information. At the receiver, the reverse operation is performed to recover the original data block. For implementation, the SLM technique needs U IDFT operations, and the number of required side information bits is $\lceil \log_2 U \rceil$ for each data block. This approach is applicable with all types of modulation and any number of subcarriers. The amount of PAPR reduction for SLM depends on the number of phase sequences U and the design of the phase sequences.

TABLE I. PAPR OF DIFFERENT SUBCARRIERS IN SLM

| No. of Sub-carriers | PAPR Before SLM (dB) | PAPR after SLM for different phase factors | | | | Least PAPR (dB) | Diff. in PAPR (dB) |
|---------------------|----------------------|--|------|------|------|-----------------|--------------------|
| 64 | 6.32 | 5.13 | 4.20 | 5.22 | 5.55 | 4.20 | 2.01 |
| 128 | 7.16 | 5.43 | 5.19 | 5.19 | 4.21 | 4.21 | 2.95 |
| 256 | 8.04 | 4.79 | 5.44 | 4.25 | 5.06 | 4.25 | 3.78 |

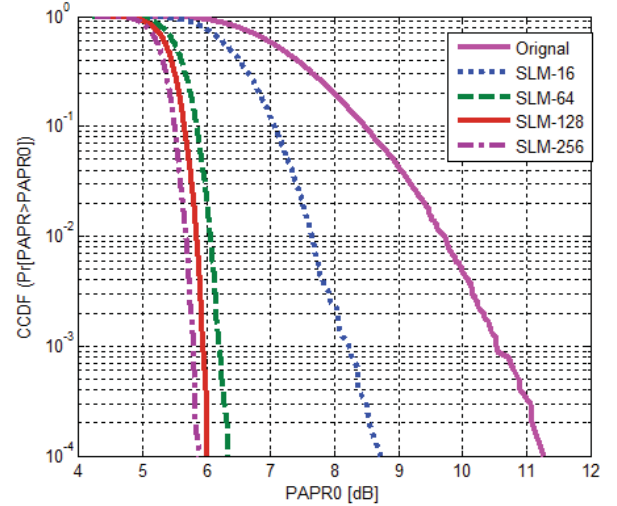

Figure 2. CCDFs of PAPR of SLM technique for $N = 16, 64, 128$ and 256 subcarriers

B. Partial Transmit Sequence Technique

In the PTS technique, an input data block of N symbols is partitioned into disjoint subblocks. The subcarriers in each subblock are weighted by a phase factor for that subblock. The phase factors are selected such that the PAPR of the combined signal is minimized.

Figure 2 shows the block diagram of the PTS technique. In the ordinary PTS technique [7] input data block \mathbf{X} is partitioned into M disjoint subblocks $\mathbf{X}_m = [X_{m,0}, X_{m,1}, \dots, X_{m,N-1}]^T$, $m = 1, 2, \dots, M$, such that $\sum_{m=1}^M \mathbf{X}_m = \mathbf{X}$ and the subblocks are combined to minimize the PAPR in the time domain. The L -times oversampled time domain signal of \mathbf{X}_m , $m = 1, 2, \dots, M$, is denoted as $\mathbf{x}_m = [x_{m,0}, x_{m,1}, \dots, x_{m,NL-1}]^T$. \mathbf{x}_m , $m = 1, 2, \dots, M$, is obtained by taking an IDFT of length NL on \mathbf{X}_m concatenated with $(L-1)N$ zeros. These are called the partial transmit sequences. Complex phase factors, $b_m = e^{j\phi_m}$, Where $m = 1, 2, \dots, M$, are introduced to combine the PTS. The set of phase factors is denoted as a vector $\mathbf{b} = [b_1, b_2, \dots, b_M]^T$. The time domain signal after combining is given by

$$\mathbf{X}'(\mathbf{b}) = \sum_{m=1}^M b_m \cdot \mathbf{X}_m \quad (4)$$

Where $\mathbf{x}'(\mathbf{b}) = [x'_0(\mathbf{b}), x'_1(\mathbf{b}), \dots, x'_{NL-1}(\mathbf{b})]^T$. The objective is to find the set of phase factors that minimizes the PAPR. Minimization of PAPR is related to the minimization of $\max_{0 \leq k \leq NL-1} |x'_k(\mathbf{b})|$. In general, the selection of the phase factors is limited to a set with a finite number of elements to reduce the search complexity. The set of allowed phase factors is written as

$$P = \{e^{j2\pi l/W} \mid l = 0, 1, \dots, W-1\} \quad (5)$$

Where W is the number of allowed phase factors. In addition, we can set $b_1 = 1$ without any loss of performance. So, we should perform an exhaustive search for $(M-1)$ phase factors. Hence, W^{M-1} sets of phase factors are searched to find the optimum set of phase factors. The search complexity increases with the number of subblocks M . PTS needs M IDFT operations for each datablock, and the number of required side information bits is $\lceil \log_2 W^{M-1} \rceil$, where $\lceil y \rceil$ denotes the exponentially smallest integer that does not exceed y . The amount of PAPR reduction depends on the number of subblocks M and the number of allowed phase factors W . Another factor that may affect the PAPR reduction performance in PTS is the subblock partitioning, which is the method of division of the subcarriers into multiple disjoint subblocks.

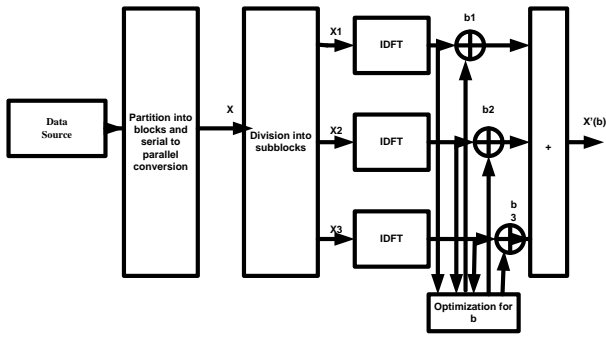

Figure 3. Block diagram of PTS scheme [7].

There are three kinds of subblock partitioning schemes: adjacent, interleaved, and pseudo-random partitioning. Here, we show a simple example of the PTS technique for an OFDM system with eight subcarriers that are divided into four subblocks.

The phase factors are selected in $P = \{\pm 1\}$. Figure 3 shows the adjacent subblock partitioning for a data block X of length 8. The original data block X has a PAPR of 7.5 dB. There are 8 ($= 2^{4-1}$) ways to combine the

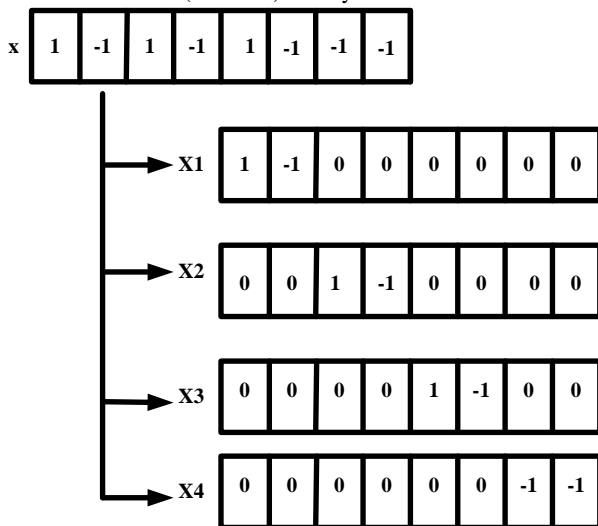

Figure 4. An example of adjacent subblock partitioning in PTS

subblocks with fixed $b_1 = 1$. Among them $[b_1, b_2, b_3, b_4]^T = [1, -1, -1, -1]^T$ achieves the lowest PAPR. The modified data block will be $X' = \sum_{m=1}^M b_m \cdot X_m = [1, -1, -1, 1, -1, 1, 1, 1]^T$ whose PAPR is 6.3 dB, resulting in a 1.2 dB reduction. In this case, the number of required IDFT operations is 4 and the amount of side information is 3 bits. The side information must be transmitted to the receiver to recover the original data block. One way to do this is to transmit these side information bits with a separate channel other than the data channel. However this results in a data rate loss.

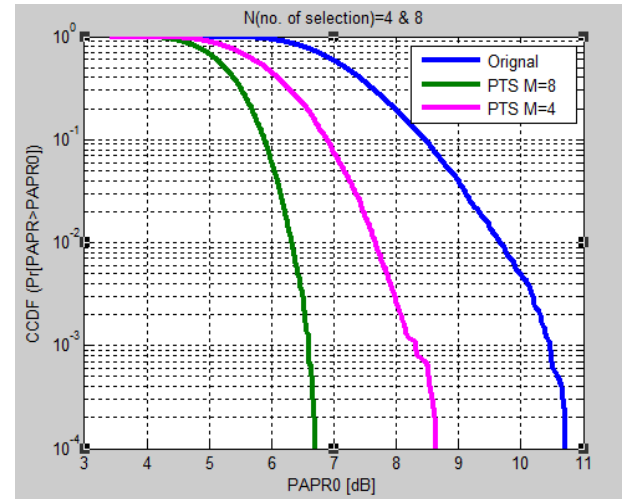

Figure 5. CCDFs of PAPR of PTS technique for $M = 4$ and 8 phase factors

4. SIGNAL DISTORTION TECHNIQUES

C. Amplitude Clipping and Filtering

The simplest technique for PAPR reduction might be amplitude clipping [1]. Amplitude clipping limits the peak envelope of the input signal to a predetermined value or otherwise passes the input signal through unperturbed. The distortion caused by amplitude clipping can be viewed as another source of noise. The noise caused by amplitude clipping falls both in-band and out-of-band. In-band distortion cannot be reduced by filtering and results in an error performance degradation, while out-of-band radiation reduces spectral efficiency. Filtering after clipping can reduce out-of-band radiation but may also cause some peak regrowth so that the signal after clipping and filtering will exceed the clipping level at some points. To reduce overall peak regrowth, a repeated clipping-and-filtering operation can be used. Generally, repeated clipping-and-filtering takes many iterations to reach a desired amplitude level. When repeated clipping-and-filtering is used in conjunction with other PAPR reduction techniques, the deleterious effects may be significantly reduced.

TABLE II. COMPARISON OF PAPR OFDM SIGNAL BEFORE AND AFTER AMPLITUDE CLIPPING [13]

| No. of Sub-carriers | Peak (mean) | Threshold (mean) | PAPR before Amplitude Clipping (dB) | PAPR before Amplitude Clipping (dB) | Diff. in PAPR (dB) |
|---------------------|-------------|------------------|-------------------------------------|-------------------------------------|--------------------|
| 64 | 0.3872 | 0.3572 | 6.60 | 5.94 | 0.65 |
| 128 | 0.2909 | 0.2609 | 7.23 | 6.33 | 0.90 |
| 256 | 0.2170 | 0.1870 | 7.87 | 6.64 | 1.23 |
| 512 | 0.1626 | 0.1326 | 8.30 | 6.59 | 1.71 |

D. Companding Technique

This is a simple and effective companding technique to reduce the PAPR of OFDM signal. The OFDM signal can be assumed Gaussian distributed, and the large OFDM signal occurs infrequently. So the companding technique can be used to improve OFDM transmission performance. A-law companding technique is used to compand the OFDM signal before it is converted into analog waveform. The OFDM signal, after taking IFFT, is companded and quantized.

After D/A conversion, the signal is transmitted through the channel. At the receiver end then the received signal is first converted into digital form and expanded. Companding is highly used in speech processing where high peaks occur infrequently. OFDM signal also exhibit similar characteristic where high peaks occur infrequently. Companding technique improves the quantization resolution of small signals at the price of the reduction of the resolution of large signals, since small signals occur more frequently than large ones. Due to companding, the quantization error for large signals is significantly large which degrades the BER performance of the system. So the companding technique improves the PAPR in expense of BER performance of the system.

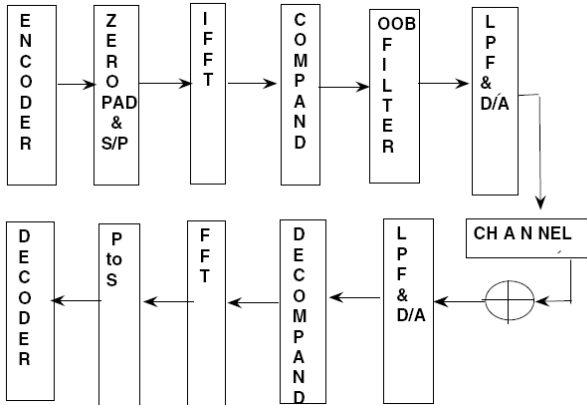

Figure 6. OFDM system using companding Technique[15]

5. COMPARISON OF TWO TECHNIQUES

Signal Scrambling have following advantages and disadvantages.

E. Advantages:

- Introduces no distortion in the transmitted signal.
- Achieve significant PAPR reduction.

F. Disadvantages:

- Loss in data rate due to transmission of several side information
- Need of powerful channel code to protect Side Information.
- It makes the system more complex & increases the transmission delay.

Signal Distortion techniques have following advantages and disadvantages.

A. Advantages:

- Simple Techniques.
- No extra side information is required.
- No loss in data rate.

B. Disadvantages:

- Distortion falls in both in band and out of band.
- Bit Error Rate increases with increase in number of subcarriers.
- Out of band radiation reduces spectral efficiency.

To summarize these techniques, various parameters are described in the table I.

| PAPR Techniques | Signal Scrambling | Signal Distortion |
|--------------------------|-------------------|-------------------|
| Distortionless Technique | Yes | No |
| Power Increase | No | No |
| Data Rate loss | Yes | No |
| Complexity at Rx | Yes | No |
| PAPR Reduction | More | Less |

TABLE III. PERFORMANCE ANALYSIS OF TWO TECHNIQUES

CONCLUSION

Orthogonal frequency division multiplexing is a form of multi carrier modulation technique with high spectral efficiency, robustness to channel fading, immunity to impulse interference. Despite of its many advantages, OFDM has two main drawbacks Viz: high peak to average power ratio (PAPR) and frequency offset. High PAPR causes saturation in power amplifiers, leading to inter modulation products among the sub carriers and disturbing out of band energy. Therefore, it is desirable to reduce the PAPR. Several techniques have been proposed

which can be categorized into two types signal scrambling and signal distortion techniques. Among signal scrambling PAPR reduction techniques, the well known SLM and PTS techniques are discussed here at length. These all are distortion less techniques. While in Signal Distortion techniques Amplitude Clipping & Filtering and Companding techniques are described. Here it is concluded that no specific PAPR reduction technique is the best solution for all multicarrier transmission systems. Rather, the PAPR reduction technique should be carefully chosen according to various system requirements. In practice, the effect of the transmit filter, D/A converter, and transmit power amplifier must be taken into consideration to choose an appropriate PAPR reduction technique.

REFERENCES

- [1] X. Li and L. J. Cimini, Jr., "Effect of Clipping and Filtering on the Performance of OFDM," *IEEE Commun.Lett.*, vol. 2, no. 5, May 1998, pp. 131–33.
- [2] A. E. Jones, T. A. Wilkinson, and S. K. Barton, "Block Coding Scheme for Reduction of Peak to Mean Envelope Power Ratio of Multicarrier Transmission Scheme," *Elect. Lett.*, vol. 30, no. 22, Dec. 1994, pp. 2098–99.
- [3] B. S. Krongold and D. L. Jones, "An Active Set Approach for OFDM PAR Reduction via Tone Reservation," *IEEE Trans. Sig. Proc.*, vol. 52, no. 2, Feb. 2004, pp. 495–509.
- [4] B. S. Krongold and D. L. Jones, "PAR Reduction in OFDM via Active Constellation Extension," *IEEE Trans. Broadcast.*, vol. 49, no. 3, Sept. 2003, pp. 258–68.
- [5] R. W. Bäuml, R. F. H. Fisher, and J. B. Huber, "Reducing the Peak-to-Average Power Ratio of Multicarrier Modulation by Selected Mapping," *Elect Lett.*, vol. 32, no. 22, Oct. 1996, pp. 2056–57
- [6] H. Breiling, S. H. Müller–Weinfurter, and J. B. Huber, "SLM Peak-Power Reduction without Explicit Side Information," *IEEE Commun. Lett.*, vol. 5, no. 6, June 2001, pp. 239–41.

- [7] S. H. Müller and J. B. Huber, "A Novel Peak Power Reduction Scheme for OFDM," *Proc. IEEE PIMRC '97*, Helsinki, Finland, Sept. 1997, pp. 1090–94.
- [8] A. D. S. Jayalath and C. Tellambura, "Adaptive PTS Approach for Reduction of Peak-to-Average Power Ratio of OFDM Signal," *Elect. Lett.*, vol. 36, no. 14, July 2000, pp. 1226–28.
- [9] L.J. Cimini, Jr. and N. R. Sollenberger, "Peak-to-Average power Ratio Reduction of an OFDM Signal Using Partial Transmit Sequences," *IEEE Commu. Lett.*, vol. 4, no. 3, Mar. 2000, pp. 86–88.
- [10] J. C. Tellambura, "Improved Phase Factor Computation for the PAR Reduction of an OFDM Signal Using PTS," *IEEE Commun. Lett.*, vol. 5, no. 4, Apr. 2001, pp. 135–37.
- [11] S. H. Han and J. H. Lee, "PAPR Reduction of OFDM Signals Using a Reduced Complexity PTS Technique," *IEEE Sig.Proc. Lett.*, vol. 11, no. 11, Nov. 2004, pp. 887–90.
- [12] C. Tellambura, "Computation of the continuous-time PAR of an OFDM signal with BPSK subcarriers," *IEEE Commun. Lett.*, vol. 5, pp.185–187, May 2001.
- [13] Abhishek Arun Dash, "OFDM systems and PAPR Reduction Techniques in OFDM systems.", Thesis, NIT, Rourkela,2010
- [14] S. H. Han, J. H. Lee, "An Overview of Peak – to – Average Power Ratio Reduction Techniques for Multicarrier Transmission", *IEEE Transaction on Wireless Communication*, April 2005.
- [15] Tao Jiang, Yang Yang, and Yong-Hua Song, "Companding Technique for PAPR Reduction in OFDM Systems Based on An Exponential Function ", *IEEE GLOBECOM 2005 proceedings*.
- [16] V. Vijayarangan and Dr. R. Sukanesh, " An Overview of Techniques for reducing peak to average power ratio and its selection criteria for orthogonal frequency division multiplexing radio systems." *Journal of Therotical and Applied Information Technology*, 2009.