

# Non Destructive Analysis of Three Phase Induction Machine Fault Diagnosis

Ramesh V  
Control and Instrumentation Engg.  
Anna University  
Chennai, India

Deepa K  
Embedded System Technology  
Anna University  
Chennai, India

Vanaja Ranjan P, Ph.D  
Embedded system Technology  
Anna University  
Chennai, India

## ABSTRACT

A Non Destructive Analysis (NDA) of Three Phase Induction Machine fault Diagnosis has been discussed in this paper. The Induction Machine Prototype was designed using Finite Element Analysis (FEM) based CAD software. Stator Inter turn Fault is designed by short circuiting the turns with current limiting resistor. The Motor current Signature Analysis (MCSA) has been done using LabVIEW based FFT with current data which is generated by 'FEM' based Induction Machine prototype. The Flux Signature Analysis also has been done and compared with MCSA. Both the Analysis are done for Different load conditions with different fault severity. The fault frequency Magnitude at various fault conditions are calculated and tabulated. This cost less NDA methodology will be the best for Machine fault Diagnosis. This paper uses a CAD package called "Infolytica Magnet 6.11.2" for the Static 2D and Transient 2D analysis.

## Keywords

3 $\Phi$  Induction Motor, Finite Element Analysis, Motor Current Signature Analysis, Flux Signature Analysis, Fast Fourier Transform.

## 1. INTRODUCTION

The main feature of this paper is to identify the stator winding fault in Machine. A *fault* in a component is usually defined as a condition of reduced capability related to specified minimal requirements and is the result of normal wear, poor specification or design, poor mounting, wrong use, or a combination of these. If a fault is not detected or if it is allowed to develop further it may lead to a *failure*.

Several surveys have been carried out on the reliability of Electrical Machines. From that surveys approximately 97% of which were cage Induction motors. The Induction motors are most widely used motors in industrial, the early detection of these deteriorating conditions in incipient phase and its removal is necessary for the prevention of external failure of the induction motors, reducing repairs costs and motor outage time [1], [2].

## 2. DIAGNOSIS OF STATOR WINDING

Various techniques are available for condition monitoring and fault diagnosis of induction motor. The stator current contains unique fault frequency components that can be used for stator winding fault detection. Vibration measurements have historically been the foundation of most on-line condition monitoring programs, but new techniques such as those involving spectral analysis of the electric line current powering the motor are becoming of significant interest. The main problem concerning the monitoring methods based on, for instance, measurement of the rotor speed, vibration, and

flux is that they are essentially invasive, requiring transducers to be fitted in or around the machine, with an obvious interruption to operation. Besides the increase in costs, the mounting of additional sensors is also a practical problem in terms of motor design and approval by the manufacturer, operator, or safety legislation authorities.

The condition monitoring schemes that rely on the analysis of the motor current is the most attractive, as the current sensors are usually installed by default in the motor control centre for other control or protection purposes. The MCSA technique is applied to machines operating under steady state conditions and has a basic requirement that for reliable diagnosis a substantial current must flow; i.e. the motor must be operating at or near full load conditions [8].

A motor failure due to stator winding faults may result in the shutdown of a generating unit or production line. One major cause of the failures is breakdown of the winding insulation leading to puncture of ground wall. Early detection of stator short winding during motor operation may eliminate consequent damage to adjacent coils. It reduces repair cost and motor outage time. In addition to the benefits gained from early detection of winding insulation breakdown, significant advantages may accrue by locating the faulted coil within the stator winding. The most common faults related to stator winding of induction motors are: phase-to-ground, phase-to-phase and short-circuit of coils of the same or different phase. These faults have several causes: hot spots in the stator winding (or stator core) resulting in high temperatures, loosening of structural parts, oil contamination, electrical discharges (in case of high voltage windings), slack core lamination, abnormal operation of the cooling system moisture, and dirt. Short-circuit related faults have specific components in the stator current frequency spectrum (equation. (1)). Incipient fault can be detected by sampling the stator current and analyzing its spectrum. The inter turn short circuit of the stator winding is the starting point of winding faults and it creates turn loss of phase winding. The short circuit current flows in the inter-turn short circuit windings. This initiates a negative MMF, which reduces net MMF of the motor phase. Therefore, the waveform of air gap flux, which is changed by the distortion of the net MMF, induces harmonic frequencies in a stator – winding current. The frequencies which appear in the spectrum showing the presence of a short-circuit fault are given by the following equation,

$$f_{sc} = f_1 \{k \pm n/p (1-s)\} \quad (1)$$

Where

- P - Pole pairs
- s - Rotor slip
- K - 1, 3, 5...
- $f_1$  - Fundamental frequency (Hz)
- $f_{sc}$  - Short circuit related frequency (Hz)
- n - Integer 1, 2, 3...

$$F_{max} = f_s/2 \tag{4}$$

Where  $F_{max}$  is the highest frequency that can be analyzed and  $f_s$  is the sampling frequency. The second relationship links the frequency resolution to the total acquisition time, which is related to the sampling frequency and the block size of the FFT and is given by the following equation (5).

$$\Delta f = 1/T = f_s/N \tag{5}$$

Where

- $\Delta f$  - The frequency resolution
- T - The acquisition time
- $f_s$  - The sampling frequency
- N - The block size

**Table I. Fault frequency calculation**

Harmonic number k	Integer value N	Fsc ( +ve case )	Fsc ( -ve case )
1	1	74.585 Hz	25.415 Hz
1	2	99.17 Hz	0 Hz
1	3	123.755 Hz	23.755 Hz
1	4	148.34 Hz	48.34 Hz
1	5	172.925 Hz	72.925 Hz
1	6	197.51Hz	97.51 Hz
1	7	222.095 Hz	72.095 Hz

The frequencies revealing the presence of short-circuit of winding are in some cases very close to frequencies related to other kinds of defect, as for example eccentricities. It is very important to distinguish one frequency from the other as shown in Table I. The fast Fourier transform (FFT) is a fast algorithm for calculating the DFT. The following equation (2) defines the DFT.

$$X(k) = \sum_{n=0}^{N-1} x(n) e^{-j\left(\frac{2\pi nk}{N}\right)} \tag{2}$$

Each frequency component is the result of a dot product of the time-domain signal with the complex exponential at that frequency and is given by the following equation (3).

$$X(k) = \sum_{n=0}^{N-1} x(n) e^{-j\left(\frac{2\pi nk}{N}\right)} = \sum_{n=0}^{N-1} x(n) \left[ \cos\left(\frac{2\pi nk}{N}\right) - j \sin\left(\frac{2\pi nk}{N}\right) \right] \tag{3}$$

The DC component is the dot product of  $x(n)$  with  $[\cos(0) - j\sin(0)]$ , or with 1.0. The first bin, or frequency component, is the dot product of  $x(n)$  with  $\cos(2\pi n/N) - j\sin(2\pi n/N)$ . Here,  $\cos(2\pi n/N)$  is a single cycle of the cosine wave and  $\sin(2\pi n/N)$  is a single cycle of a sine wave. In general, bin  $k$  is the dot product of  $x(n)$  with  $k$  cycles of the cosine wave for the real part of  $X(k)$  and the sine wave for the imaginary part of  $X(k)$ . The use of the FFT for frequency analysis implies two important relationships. The first relationship links the highest frequency that can be analyzed to the sampling frequency and is given by the following equation (4).

### 3. PROPOSED METHOD FOR FAULT DIAGNOSIS

A variety of conditions monitoring techniques and signature analysis methods have been developed. An analytical approach based on the rotating field theory and coupled circuit is often used. Online fault diagnostic system increases industrial efficiency and reliability, these are usually simulated using FFT analysis. Other emerging commercial electromagnetic CAD packages like Detection of Inter turn Fault in Three Phase Squirrel Cage Induction Motor using Finite Element Method MagNet, EMTDC, Femta fe, Slim fe, Ansoft, etc., can be used for the fault detection of non-invasive methods. Finite element analysis, which is a computer based numerical technique, is used for calculation of the machine parameters like flux density, flux linkage, torque, induced electromagnet field, etc., accurately. This analysis allows the effects of stator winding distribution, magnetic saturation and non-uniform current distributions to be considered simultaneously [9], [10].

#### 3.1 Design of Healthy Induction Motor

Generally the fault diagnosis has been analysed directly with machine's parts. In short circuit fault analysis the winding will be faulted manually because of this in some cases the machine will be failed or it may affect the nearby system. The machine cost will be increased. To Analysis purpose to avoid permanent faults in machine, the cost less NDA method has been proposed. The machine prototype has been designed using Infolytica Magnet 6.11.2 for analysis purpose. The current and flux data will be generated from this induction machine Prototype. In this method the windings are faulted virtually. FFT analysis has been done with the current and Flux data which are generated from machine prototype [10], [11]. The following design details are required.

- The main dimensions of the stator
- Details of stator windings
- Design details of rotor
- Performance characteristics

In order to get the above design, Rated output power, rated voltage, number of phases, speed, frequency, connection of stator winding etc are calculated. In addition to the above the designer must have the details regarding design equations based on which the design procedure is initiated, information regarding the various choice of various parameters, information regarding the availability of different materials and the limiting values of various performance parameters

such as iron and copper losses, no load current, power factor, temperature rise and efficiency.

### 3.2 Output Equation

Output equation AC electrical Machine is the mathematical expression which gives the relation between the various physical and electrical parameters of the electrical machine. In an induction motor the output equation can be obtained as follows equation (6).

Consider an 'm' phase machine, with usual notations

Output Q in kW = Input x efficiency

$$\text{Input to motor} = mV_{ph} I_{ph} \cos \Phi \times 10^{-3} \text{ kW} \quad (6)$$

For a 3 $\Phi$  machine m = 3

$$\text{Input to motor} = 3V_{ph} I_{ph} \cos \Phi \times 10^{-3} \text{ kW} \quad (7)$$

Assuming

$$V_{ph} = E_{ph} = 4.44 f \Phi T_{ph} K_w = 2.22 f \Phi Z_{ph} K \quad (8)$$

$$\text{Output Q} = C_o D^2 L n_s \text{ kW} \quad (9)$$

$$\text{Where } C_o = (11 B_{av} q K_w \eta \cos \Phi \times 10^{-3}) \quad (10)$$

$V_{ph}$  - Phase voltage

$I_{ph}$  - Phase current

$Z_{ph}$  - No of conductors/phase

$T_{ph}$  - No of turns/phase

$N_s$  - Synchronous speed in rpm

$n_s$  - Synchronous speed in rps

$p$  - No of poles

$q$  - Specific electric loading

$\Phi$  - Air gap flux/pole

$B_{av}$  - Average flux density

$K_w$  - Winding factor

$\eta$  - Efficiency

$\cos \Phi$  - Power factor

$D$  - Diameter of the stator

$L$  - Gross core length

$C_o$  - Output coefficient

As power factor plays a very important role the performance of induction motors it is advisable to design an induction motor for best power factor unless specified. Hence to obtain the best power factor the following equations (11) and (12) will be usually assumed for separation of D and L.

$$\text{Pole pitch/ Core length} = 0.18/\text{pole pitch} \quad (11)$$

$$\text{or } (\pi D/p) / L = 0.18/(\pi D/p) \quad (12)$$

$$\text{i.e. } D = 0.135P\sqrt{L}$$

$$\text{Where D and L are in meter.} \quad (13)$$

### 3.3 Turns per phase

EMF equation of an induction motor is given by

$$E_{ph} = 4.44f\Phi T_{ph}k_w \quad (14)$$

Hence turns per phase can be obtained from emf equ.(15)

$$T_{ph} = E_{ph} / 4.44f\Phi k_w \quad (15)$$

Generally the induced emf can be assumed to be equal to the applied voltage per phase

$$\text{Flux/pole, } \Phi = B_{av} \times \pi DL/P \quad (16)$$

Winding factor 'kw' may be assumed as 0.955 for full pitch distributed winding unless otherwise specified. Number of conductors /phase,  $Z_{ph} = 2 \times T_{ph}$ , and hence Total number of stator conductors  $Z = 6 T_{ph}$  and conductors /slot  $Z_s = Z/S_s$  or  $6 T_{ph}/S_s$ , where  $Z_s$  is an integer for single layer winding and even number for double layer winding.

### 3.4 Assumption Made

Here 3 $\Phi$ , 415V, 50Hz, P=4,2HP induction motor has been Designed using Infolytica MagNet 6.11.2 software.

Specific Magnetic loading,  $B_{av}$  - 0.48 Tesla

Specific Electric loading,  $q$  - 26000 ac/m

Full load efficiency,  $\eta$  - 0.88

Full load power factor  $\cos\Phi$  - 0.86

Winding factor  $K_w$  - 0.955

### 3.5 Calculated Dimension

Output coefficient  $C_o$  - 99.218 Kw

$n_s$  - 25rps

$D^2L$  -  $6.015 \times 10^{-4}$

$D=0.115m$  - 115mm

$L=0.0504m$  - 50mm

No. of slots/pole/phase - 1

Stator slots =  $1 \times 4 \times 3$  - 12

Turns per phase - 575

### 3.6 Stator winding

The windings used in rotating electrical machines can be classified as Concentrated Windings, Distributed Windings, Closed Windings, and Open Windings.

#### 3.6.1 Distributed Windings

All the winding turns are arranged in several full-pitch or fractional-pitch coils. These coils are then housed in the slots spread around the air-gap periphery to form phase winding. Examples of distributed winding are Stator and rotor of induction machines. The armatures windings of both synchronous and D.C. machines, in general, are classified under two main heads, namely, closed and open winding. RMF Equation will be given by the equation (17). The winding diagram has been shown in fig. 1.

$$F_{total} = \frac{3}{2} F_{max} \cos(\theta_{ae} - \omega_e t) + \frac{F_{max}}{2} \left[ \cos(\theta_{ae} + \omega_e t) + \cos(\theta_{ae} + \omega_e t + 120^\circ) + \cos(\theta_{ae} + \omega_e t - 120^\circ) \right] \quad (17)$$

The second term vector sums to zero, so equation (17) becomes,

$$F_{total} = \frac{3}{2} F_{max} \cos(\theta_{ae} - \omega_e t) \quad (18)$$

### 3.7 Stator winding Design

Stator inner diameter	- 360mm
Total slots	- 12
Slot width=teeth width	- 15mm
P	- 4
Pole pitch=12/4	- 3
Coil span	- 3
Slot/pole/phase	- 1
Full pitched (Pole pitch=coil span)	

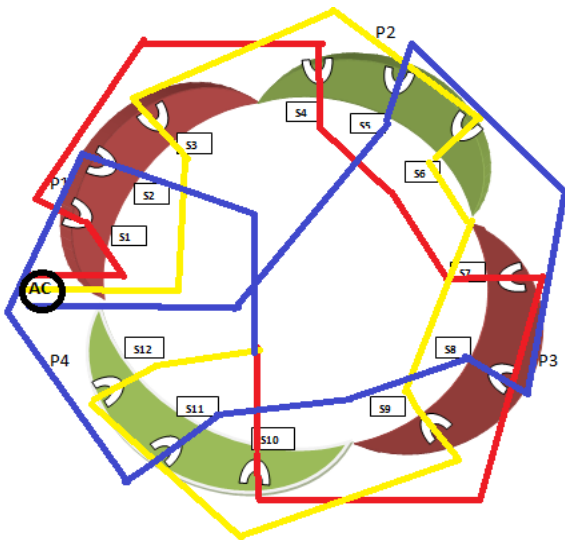

Fig 1: Stator winding

### 3.8 Induction Machine Prototype

Three phase induction machine has been designed using Infolytica MagNet. The designed Machine having speed of 400rpm and 3.5 Nm Torque. The stator winding were made with some short circuited turns for fault condition. The current data has been exported into excel file for Signature analysis. The Designed Induction Motor mesh diagram has been shown in fig. 2. This Machine has 4 Pole, 12 Slots.

## 4. MOTOR CURRENT SIGNATURE ANALYSIS

The Motor Current Signature Analysis is the Power full tool for Machine Fault diagnosis. For analysis purpose the designed three phase induction machine has been faulted by short circuiting stator inter turn winding. The current data and

corresponding speed taken for each fault separately. The FFT based power spectrum also done using LabVIEW program with current data [3], [6].

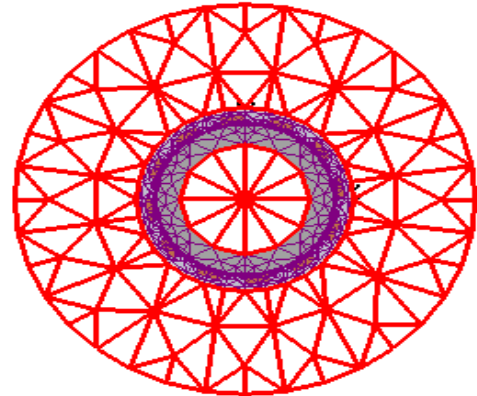

Fig 2: Mesh diagram for Three Phase Induction Machine

First the current data and speed of the healthy machine with no load condition has been taken. The fault frequency also calculated but the fault frequency does not increase in magnitude as shown in fig. 3. Next the current data taken for healthy machine with full load and FFT based Spectrum has been done as shown in fig. 4. Both the cases the fault frequency magnitude do not rise.

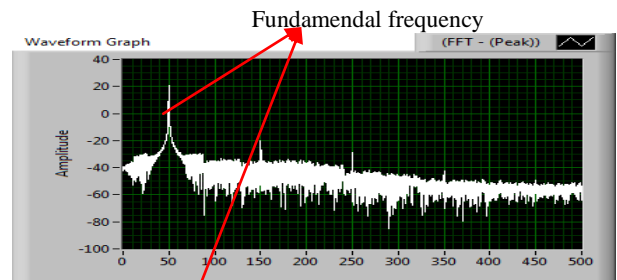

Fig 3: Healthy machine with no load

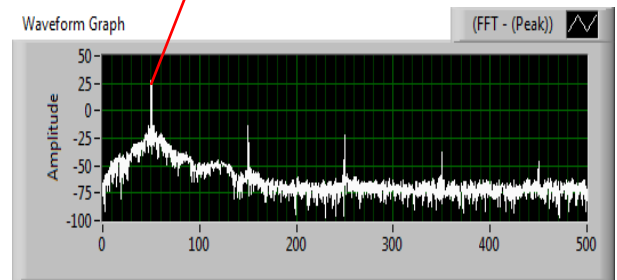

Fig 4: Healthy machine with Full load

The winding inter turn fault made as stated earlier. The fault increased linearly as 1%, 2%, 20%, 50% of Turns short circuited. The following figures will show that whenever fault occurred, the speed will be changed and slip will be changed correspondingly so the fault frequency also will be changed, the corresponding FFT spectrum will show the fault frequency rise in magnitude with respect to the fault severity.

The figs. 5, 6, 7 and 8 show power spectrum for 1%, 2%, 20%, and 50% of winding fault respectively which shows the rise in magnitude of fault frequency with respect to fault severity.

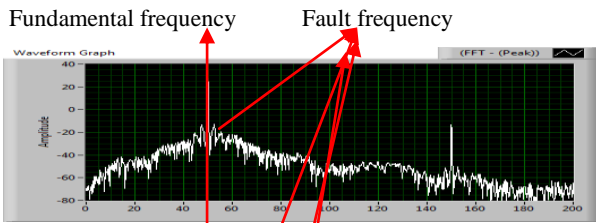

Fig 5: Winding Fault machine (1% winding faulted)

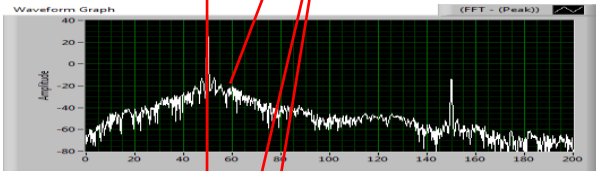

Fig 6: Winding Fault machine (2% winding faulted)

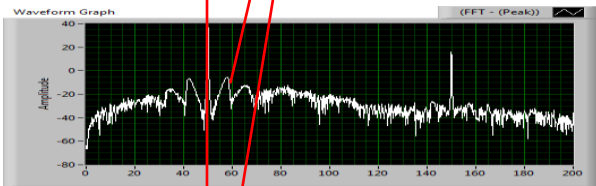

Fig 7: Winding Fault machine (20% winding faulted)

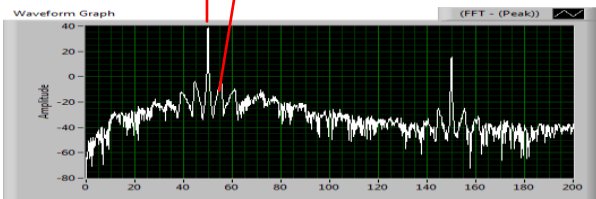

Fig 8: Winding Fault machine (50% winding faulted)

The FFT graphs clearly showing that if fault occurred then the fault frequency magnitude starts to rise and according to the fault severity the magnitude also increased.

## 5. MAGNETIC FLUX MONITORING

As previously shown, electrical motors experience a wide range of mechanical and electrical problems common to most machinery, such as unbalance, misalignment, bearing faults, and stator winding fault but electrical motors also experience their own specific set of problems, which are a result of electro-magnetically generated fields in the stator and rotor. In this respect, monitoring devices relying on the information provided by the electromagnetic fluxes produced by any small unbalance in the magnetic or electric circuit of motors may be efficiently used in addition to or as alternatives to the widely-used current monitoring. The external leakage flux was selected as the most practical signals containing the needed information for the detection of stator winding fault [12].

### 5.1 Flux Signature Analysis

The same induction machine prototype has been used for The Flux Signature Analysis (FSA). The FSA has been done with flux data which is generated from Induction machine Prototype. The flux signature analysis is also a good for machine fault diagnosis. Finally the MCSA (Motor Current Signature Analysis) and FSA (Flux Signature Analysis) both are compared.

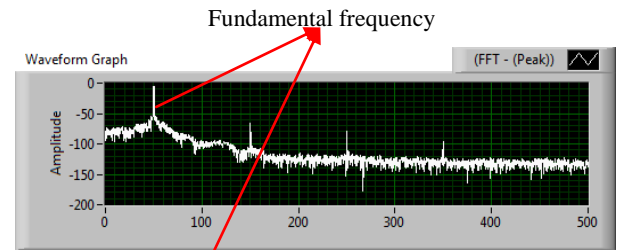

Fig 9: Healthy machine

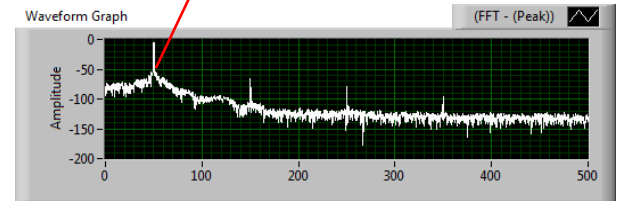

Fig 10: Healthy machine with Full load

The figs. 11, 12, 13 and 14 will show Power spectrum for 1%, 2%, 20%, and 50% of winding fault respectively which shows the rise in magnitude of fault frequency with respect to fault severity.

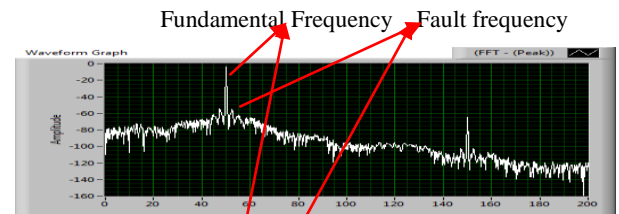

Fig 11: Winding Fault machine (1% winding faulted)

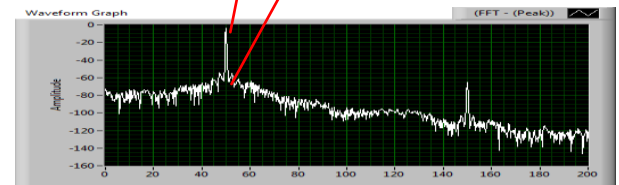

Fig 12: Winding Fault machine (2% winding faulted)

In this Power spectrum density analysis 20% of winding fault has been made in stator winding. The fault frequency has been calculated as 43 Hz and 56 Hz and the FFT showing the rise in Magnitude of corresponding fault frequency with respect to the fault severity.

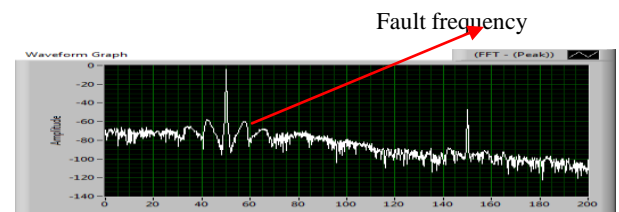

Fig 13: Winding Fault machine (20% winding faulted)

In this PSD analysis 50% of winding fault has been made in stator winding. The fault frequency has been calculated as 46 Hz and 53 Hz and the FFT showing the rise in Magnitude of corresponding fault frequency with respect to the fault severity.

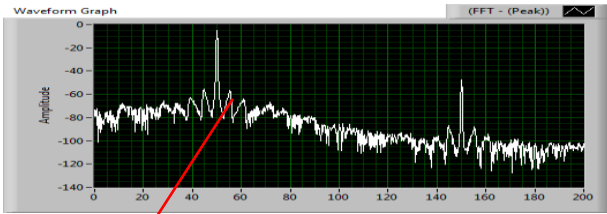

Fig 14: Winding Fault machine (50% winding faulted)

Fault frequency

### 6. COMPARISON TABLE

The CSA and FSA method has been compared in the following Table II. The fault frequency magnitude will be raised with respect to the fault severity in both the cases. The fault frequencies have been calculated for each fault separately based on slip.

Table II. Comparison Table between CSA and FSA

Machine Status	Current Signature Analysis			Flux Signature Analysis
	Slip (s)	Fault frequencies (fsc1,fsc2)Hz	Magnitude	Magnitude
Healthy Machine	0.6	40,60	-25	-75
	0.61	40.25,59.75	-25	-75
1% winding Fault	0.7	42.5,57.5	-20	-65
2% winding Fault	0.71	42.75,57.25	-20	-65
20% winding Fault	0.73	43.25,56.75	-5	-58
50% winding Fault	0.87	46.75,53.25	-1	-55

### 7. FLUX MAGNITUDE MONITORING

One more monitoring method also discussed in this topic. The flux magnitude has been monitored and readings have been taken for different fault conditions. The flux magnitude will be decreased when short circuit fault occurred. Fig. 15 shows an inter-turn short circuit between two points, a and b, of a complete stator winding. The path to the circulating current between these points is closed and the path A–A’ can be expanded into two independent circuits. Fig. 15 shows that the two currents, the phase current and the current which flows in the short circuited part, produce opposite MMFs. Therefore, inter-turn short circuits have a cumulative effect in decreasing the MMF.

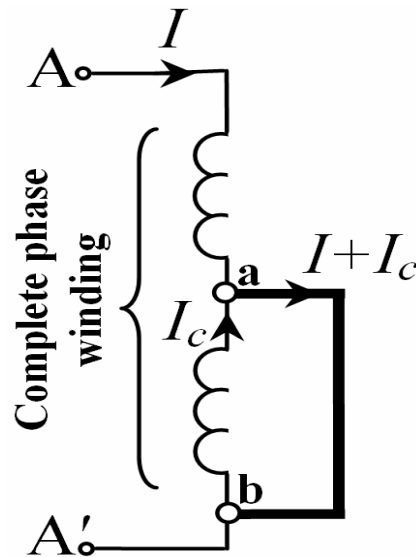
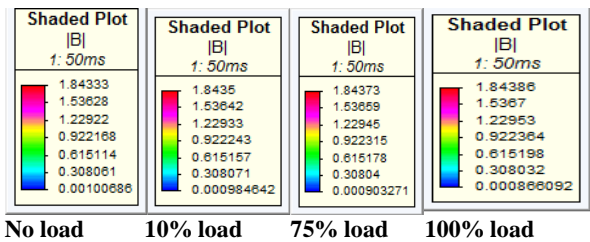

Fig 15: Short circuit Model

### 7.1 HEALTHY MACHINE

Flux magnitude have been measured for the Healthy machine and Different Fault conditions Using Infolytica MagNet software based Induction machine Prototype as shown in Fig. 16. The flux pattern also projected as shown in Fig. 17.



No load 10% load 75% load 100% load

Fig 16: Flux Magnitude for Different load conditions

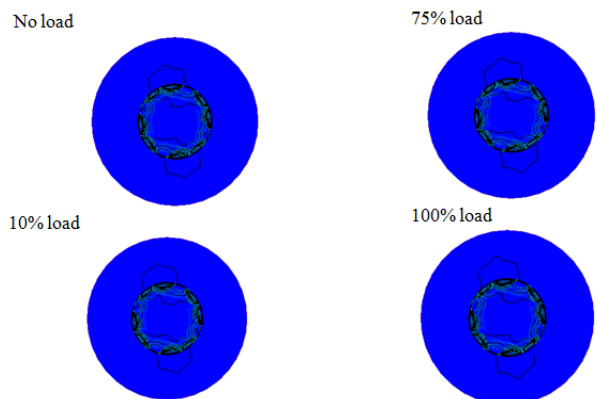
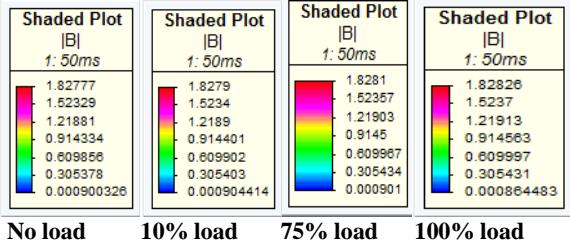

Fig 17: Flux Pattern for Healthy Machine at different load conditions

The following figures will show the flux magnitude at different load conditions and fault conditions.

### 7.2 5 Turns Shorted



### 7.5 100 Turns Shorted

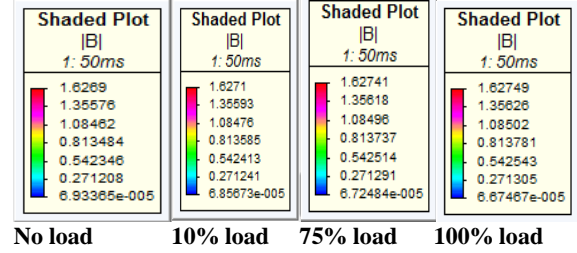

### 7.3 10 Turns Shorted

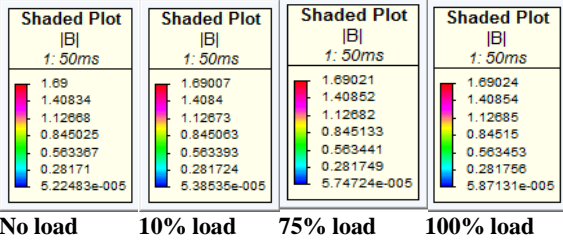

### 7.6 275 Turns Shorted

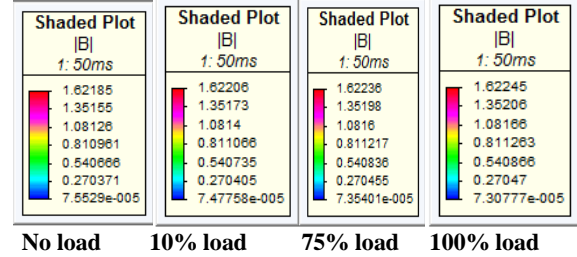

### 7.4 25 Turns Shorted

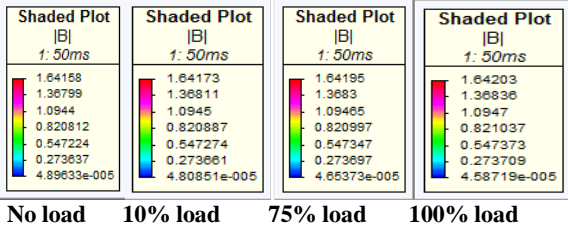

### 7.7 575 Turns Shorted

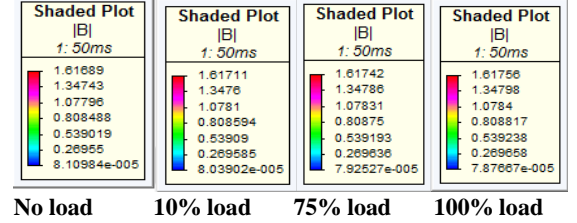

Fig 18: Flux Magnitude for less number of turns short circuited

Fig 19: Flux Magnitude for more number of turns short circuited

Table III. Flux Magnitude for different loads and fault conditions

Machine condition	Flux magnitude (Wb)			
	No load	10% load	75 % load	100% load
Healthy machine	1.8433	1.8435	1.84373	1.84386
5 Turns shorted	1.82777	1.8279	1.8281	1.82826
10 Turns shorted	1.69	1.69007	1.69021	1.69024
25 Turns Shorted	1.64158	1.64173	1.64195	1.64203
100 Turns Shorted	1.6269	1.6271	1.62741	1.62749
275 Turns shorted	1.62185	1.62206	1.62236	1.62245



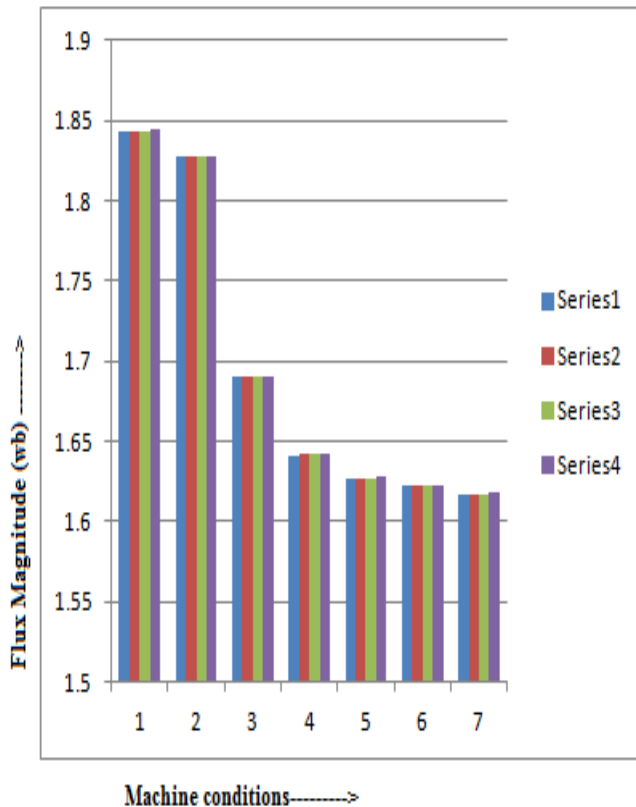

**Fig 19: Flux Magnitude for different loads and fault conditions**

The different readings are tabulated in Table III. The chart shows the decreases in flux magnitude when fault condition occurred and increased in different load conditions. The load conditions are shown as series 1, series 2, series 3 and series 4. The machine status are shown as 1, 2, 3 etc.

## 8. CONCLUSIONS

The Motor Current signature Analysis and Flux Signature Analysis were analysed and finally both the results were compared. The FSA method will be suitable for all types of load but in Practical case which should have high costly flux sensor. So The MCSA method is the best and economic one. The finite Element Analysis based Non Destructive Analysis (NDA) and cost less method will be the best for Analysis of Machine Fault Diagnosis.

## 9. REFERENCES

- [1] Ahcène Bouzida, Omar Touhami, Rachid Ibtouen, Adel Belouchrani, Maurice Fadel, and A. Rezzoug "Fault Diagnosis in Industrial Induction Machines Through Discrete Wavelet Transform". IEEE Transactions on Industrial Electronics, vol. 58, no. 9, September 2011.
- [2] Amine Yazidi, Member, IEEE, Humberto Henao. "A Web-Based Remote Laboratory for Monitoring and Diagnosis of AC Electrical Machines" IEEE transactions on industrial electronics, vol. 58, no. 10, October 2011.
- [3] Collamatit L, Filippettit,G; Fanceschini S', Piran, C Tassod "Induction Machine Stator Fault alp-Line Diagnosis based on LabVIE'W Enviroment". 0-7803-31-09-5/96/\$5.00 1996 IEEE.
- [4] Cusido, J.Tech. Univ. of Catalonia, Barcelona Romeral, L.; Ortega, 3.5 "Fault Detection in Induction Machines Using Power Spectral Density in Wavelet Decomposition".
- [5] Haoxiang Lang, Ying Wang, and Clarence W. de Silva Industrial Automation Laboratory Department of Mechanical Engineering. "An Automated Industrial Fish Cutting Machine: Control, Fault Diagnosis and Remote Monitoring" The University of British Columbia Vancouver, BC, Canada {hxlang; ywang; desilva}@mech.ubc.ca. Proceedings of the IEEEInternational Conference on Automation and Logistics Qingdao, China September 2008.
- [6] Jordi Cusidó, Student Member, IEEE, Luis Romeral, Member, IEEE, Juan A. Ortega, Member, IEEE, Javier A. Rosero, and Antonio García Espinosa, Member, IEEE "Fault Detection in Induction Machines Using Power Spectral Density in Wavelet Decomposition". IEEE Transactions on Industrial Electronics, Vol. 55, NO. 2, February 2008.
- [7] Joya Kappatou, Athanasios N. Safacas University of Patras, Department of Electrical and Computer Engineering Electromechanical Energy Conversion Laboratory. Titled "Finite Element Inductance Calculations in 3-phase Squirrel-Cage Induction Machines with Broken Rotor Bars" 1-4244-0194-1/06/2006 IEEE.
- [8] Luis Alberto Pereira I, Daniel da Silva Gazzana2. "Rotor Broken Bar Detection and Diagnosis in Induction Motors Using Stator Current Signature Analysis and Fuzzy Logic". The 30th Annual Conference of the IEEE Industrial Electronics Society, November 2 - 6, 2004, Busan, Korea.
- [9] Stephen Nawrocki, Lei Hao, Xidong Tang General Motor R&D Center, Warren MI. "Modeling & Analysis of Weld Short Faults of Bar-Wound Propulsion IPM Machine Part II: Phase-to-Phase Short" 978-1-61284-247-9/11/2011 IEEE.
- [10] Sudar vizhi,A, Nagaraj S, Dr. RamaReddy, S Department of Electrical and Electronics Engineering, Jerusalem College of Engineering, Chennai, India. "Detection And Analysis of Broken Bar in Three Phase Squirrel Cage Induction Motor using FEM". 2012 International Conference on Computing, Electronics and Electrical Technologies [ICCEET].
- [11] Vaseghi B, N. Takorabet, F. Meibody-Tabar "Modeling of 1M with Stator Winding Inter-turn Fault Validated by FEM". Proceedings of the 2008 International Conference on Electrical Machines.
- [12] K.Vinoth Kumar, S.Suresh KumarI.J. "LabVIEW based Condition Monitoring of Induction Machines" Intelligent Systems and Applications, 2012, 3, 56-62. DOI:10.5815/ijisa.2012.03.08.